

Clinical Practice Guidelines
MOH/P/PAK/354.17(GU)

Management of Asthma

in Adults



Ministry of Health Malaysia



Malaysian Thoracic Society



Academy of Medicine Malaysia

Published by:

Malaysian Health Technology Assessment Section (MaHTAS)
Medical Development Division, Ministry of Health Malaysia
Level 4, Block E1, Precinct 1
Federal Government Administrative Centre 62590
Putrajaya, Malaysia

Copyright

The copyright owner of this publication is MaHTAS. Content may be reproduced in any number of copies and in any format or medium provided that a copyright acknowledgement to MaHTAS is included and the content is not changed, not sold, nor used to promote or endorse any product or service, and not used in an inappropriate or misleading context.

ISBN: 978-967-2173-14-4

Available on the following websites:

<http://www.moh.gov.my>

<http://www.acadmed.org.my>

<http://mts.org.my>

Also available as an app for Android and IOS platform: MyMaHTAS

STATEMENT OF INTENT

These clinical practice guidelines (CPG) are meant to be guides for clinical practice, based on the best available evidence at the time of development. Adherence to these guidelines may not necessarily guarantee the best outcome in every case. Every healthcare provider is responsible for the management of his/her unique patient based on the clinical picture presented by the patient and the management options available locally.

UPDATING THE CPG

These guidelines were issued in 2017 and will be reviewed in a minimum period of four years (2021) or sooner if new evidence becomes available. When it is due for updating, the Chairman of the CPG or National Advisor of the related specialty will be informed about it. A discussion will be done on the need for a revision including the scope of the revised CPG. A multidisciplinary team will be formed and the latest systematic review methodology used by MaHTAS will be employed.

Every care is taken to ensure that this publication is correct in every detail at the time of publication. However, in the event of errors or omissions, corrections will be published in the web version of this document, which is the definitive version at all times. This version can be found on the websites mentioned above.

TABLE OF CONTENTS

No.	Title	Page
	Levels of Evidence and Grading Recommendations, Assessment, Development and Evaluation	i
	Key Recommendations	ii
	Guidelines Development and Objectives	iv
	Development Group	vii
	Review Committee	viii
	External Reviewers	ix
	Algorithm 1. Stepwise Treatment Ladder in Stable Asthma	x
	Algorithm 2. Management of Acute Exacerbation of Asthma in Primary Care	xi
	Algorithm 3. Management of Acute Exacerbation of Asthma in Emergency Department	xii
1.	INTRODUCTION	1
2.	EPIDEMIOLOGY AND RISK FACTORS	1
	2.1 Epidemiology	1
	2.2 Risk Factors	2
3.	DIAGNOSIS	4
4.	GENERAL PRINCIPLES OF MANAGEMENT	7
5.	ASTHMA SELF-MANAGEMENT	8
	5.1 Role of Self-management	8
	5.2 Written Asthma Action Plan	8
	5.3 Education Modality	8
6.	STABLE ASTHMA	11
	6.1 Assessment of Severity for Future Risk	12
	6.2 Criteria for Step Up/Step Down	14
	6.3 Treatment	14
	6.3.1 As-needed reliever therapy	16
	6.3.2 Controller therapy (In addition to as-needed reliever inhaler)	17
	a. Step 1	18
	b. Step 2	18
	c. Step 3	19
	d. Step 4	20
	e. Step 5	20

TABLE OF CONTENTS

No.	Title	Page
7.	NON-PHARMACOLOGICAL TREATMENT	23
8.	ACUTE EXACERBATION OF ASTHMA	24
8.1	Assessment of Severity	24
8.2	Treatment	26
8.2.1	Oxygen	26
8.2.2	β_2 -agonists	26
8.2.3	Ipratropium bromide	27
8.2.4	Corticosteroids	28
8.2.5	Magnesium sulphate	29
8.2.6	Other treatments	29
8.3	Monitoring and Evaluation	30
8.4	Criteria for admission/discharge	31
9.	SPECIAL GROUPS	33
9.1	Asthma in Pregnancy	33
9.2	Occupational Asthma	33
9.3	Exercise-Induced Bronchoconstriction	34
9.4	Asthma-Chronic Obstructive Pulmonary Disease Overlap	36
9.5	Asthma with Co-Morbidities	37
9.6	Difficult to Control Asthma	39
10.	REFERRAL	41
11.	IMPLEMENTING THE GUIDELINES	41
11.1	Facilitating and Limiting Factors	41
11.2	Potential Resource Implications	42
	REFERENCES	43
	Appendix 1: Example of Search Strategy	48
	Appendix 2: Clinical Questions	49
	Appendix 3: Peak Expiratory Flow Rate Variability	51
	Appendix 4: Peak Expiratory Flow Normogram	52
	Appendix 5: Written Asthma Action Plan	53
	Appendix 6: Asthma Control Test (English & Malay version)	54
	Appendix 7: Common Medications in Asthma	56
	Appendix 8: Inhaler Devices and Techniques	63
	List of Abbreviations	68
	Acknowledgement	69
	Disclosure Statement	69
	Source of Funding	69

LEVELS OF EVIDENCE

Level	Study design
I	Evidence from at least one properly randomised controlled trial
II-1	Evidence obtained from well-designed controlled trials without randomisation
II-2	Evidence obtained from well-designed cohort or case-control analytic studies, preferably from more than one centre or group
II-3	Evidence from multiple time series with or without intervention. Dramatic results in uncontrolled experiments (such as the results of the introduction of penicillin treatment in the 1940s) could also be regarded as this type of evidence
III	Opinions of respected authorities based on clinical experience; descriptive studies and case reports; or reports of expert committees

SOURCE: US / CANADIAN PREVENTIVE SERVICES TASK FORCE 2001

FORMULATION OF RECOMMENDATION

In line with new development in CPG methodology, the CPG Unit of MaHTAS is in the process of adapting **Grading Recommendations, Assessment, Development and Evaluation (GRADE)** in its work process. The quality of each retrieved evidence and its effect size are carefully assessed/reviewed by the CPG Development Group. In formulating the recommendations, overall balances of the following aspects are considered in determining the strength of the recommendations:-

- overall quality of evidence
- balance of benefits versus harms
- values and preferences
- resource implications
- equity, feasibility and acceptability

KEY RECOMMENDATIONS

The following recommendations are highlighted by the CPG Development Group as the key recommendations that answer the main questions addressed in the CPG and should be prioritised for implementation.

Diagnosis

- Diagnosis of asthma should be made based on typical clinical history and supported by positive obstructive airflow reversibility with spirometry. The higher the reversibility (or peak flow variability), the higher the probability of asthma.

Asthma Self-Management

- All asthma patients should be offered self-management education.
 - Written asthma action plan (WAAP) is the preferred option.
- WAAP should be based on symptoms and/or peak expiratory flow readings.

Stable Asthma

- Inhaler technique and adherence to treatment should be assessed at every clinic visit and before escalating treatment in the management of asthma.
- Inhaled short-acting β_2 -agonists (SABA) are the reliever of choice in stable asthma.
- Oral SABA should be avoided in asthma due to their side effects.
- Low dose of budesonide/formoterol or beclometasone/formoterol may be used as a single inhaler for maintenance and reliever therapy in moderate to severe asthma.
- Inhaled long-acting β_2 -agonists without inhaled corticosteroids (ICS) should not be used as monotherapy in stable asthma.
- Low to moderate dose of ICS are the preferred maintenance therapy in asthma.
- Initiation of ICS should not be delayed in symptomatic asthma.
- Low dose ICS should be considered in steroid-naïve symptomatic asthma.

Non-Pharmacological Treatment

- All asthma patients should be advised to quit smoking and offered smoking cessation programme.

Acute Exacerbation of Asthma

- Rapid clinical assessment of severity should be performed in all acute exacerbation of asthma.
- Asthma treatment should be initiated immediately based on severity of asthma.
- Controlled flow oxygen therapy should be given to all hypoxic asthma patients to maintain oxygen saturation of $\geq 94\%$.
- In acute exacerbation of asthma,
 - inhaled β_2 -agonists is the first-line treatment
 - combination of short-acting muscarinic antagonists and short-acting β_2 -agonists may be given in emergency settings
 - systemic corticosteroids should be given to all patients with the acute condition
- Intravenous magnesium sulphate should be considered in acute severe and life-threatening asthma.
- Monitoring and evaluation of asthma severity should include peak expiratory flow (PEF) and oxygen saturation. In severe and life-threatening asthma,
 - PEF measurement is not necessary
 - arterial blood gases should be done if readily available
- Early referral for critical care should be considered for asthma patients who respond poorly to optimal treatment and at-risk of respiratory failure.

Referral

- Asthma patients with the following conditions should be referred to specialists with experience in asthma management for further evaluation:
 - diagnosis of asthma is not clear
 - suspected occupational asthma
 - poor response to asthma treatment
 - severe/life-threatening asthma exacerbations
 - asthma in pregnancy
 - asthma with multiple co-morbidities

GUIDELINES DEVELOPMENT AND OBJECTIVES

GUIDELINES DEVELOPMENT

The members of the Development Group (DG) for these Clinical Practice Guidelines (CPG) were from the Ministry of Health (MoH), Ministry of Higher Education and private healthcare. There was active involvement of a multidisciplinary Review Committee (RC) during the process of the CPG development.

Consensus guidelines on the same topic were issued in 1996 and 2002. This edition is the first evidence-based CPG developed using systematic review methodology and the scope expanded/added on risk factors, diagnosis, self-management, treatment on both stable and acute exacerbation of asthma, special groups and referral. A literature search was carried out using the following electronic databases: mainly Medline via Ovid and Cochrane Database of Systemic Reviews and others e.g. Pubmed and Guidelines International Network (refer to **Appendix 1** for **Example of Search Strategy**). The search was limited to literature published in the last fifteen years (1996 onwards), on humans and in English. In addition, the reference lists of all retrieved literature and guidelines were searched to further identify relevant studies. Experts in the field were also contacted to identify further studies. All searches were conducted from 8 July 2015 to 22 September 2016. Literature searches were repeated for all clinical questions at the end of the CPG development process allowing any relevant papers published before 31 July 2017 to be included. Future CPG updates will consider evidence published after this cut-off date. The details of the search strategy can be obtained upon request from the CPG Secretariat.

References were also made to other CPGs on asthma e.g. Global Strategy for Asthma Management and Prevention (Global Initiative for Asthma, 2017) and British Guideline on the Management of Asthma (British Thoracic Society & Scottish Intercollegiate Guidelines Network, 2016). The CPGs were evaluated using the Appraisal of Guidelines for Research and Evaluation (AGREE) II prior to them being used as references.

A total of 32 clinical questions were developed under five different sections. Members of the DG were assigned individual questions within these sections (refer to **Appendix 2** for **Clinical Questions**). The DG members met 26 times throughout the development of these guidelines. All literature retrieved were appraised by at least two DG members using Critical Appraisal Skill Programme checklist, presented in evidence tables and further discussed in each DG meetings. All statements and recommendations formulated after that were agreed upon by both the DG and RC. Where evidence was insufficient, the

recommendations were made by consensus of the DG and RC. This CPG is based largely on the findings of systematic reviews, meta-analyses and clinical trials, with local practices taken into consideration.

The literature used in these guidelines were graded using the US/ Canadian Preventive Services Task Force Level of Evidence (2001), while the grading of recommendation was done using the principles of GRADE (refer to the preceding page). The writing of the CPG follows strictly the requirement of AGREE II.

On completion, the draft of the CPG was reviewed by external reviewers. It was also posted on the MoH Malaysia official website for feedback from any interested parties. The draft was finally presented to the Technical Advisory Committee for CPG, and the HTA and CPG Council MoH Malaysia for review and approval. Details on the CPG development methodology by MaHTAS can be obtained from Manual on Development and Implementation of Evidence-based Clinical Practice Guidelines published in 2015 (available at <http://www.moh.gov.my/index.php/pages/view/117>).

OBJECTIVES

To provide evidence-based recommendations in the management of asthma in adults on the following aspects:

- diagnosis and assessment
- treatment and follow-up

CLINICAL QUESTIONS

Refer to **Appendix 2**

TARGET POPULATION

Inclusion Criteria

- Adults (≥ 18 years old) with asthma

Exclusion Criteria

- “Brittle Asthma” (sudden, unpredictable and severe life-threatening asthma)
- ICU management of asthma

TARGET GROUP/USERS

This document is intended to guide those involved in the management of asthma in adults at any healthcare level including:

- i. Doctors
- ii. Allied health professionals
- iii. Trainees and medical students
- iv. Patients and their advocates
- v. Professional societies

HEALTHCARE SETTINGS

Primary and secondary/tertiary care settings

DEVELOPMENT GROUP

Chairperson

Dr. Andrea Ban Yu-lin
Consultant Respiratory Physician
Pusat Perubatan Universiti Kebangsaan Malaysia, Kuala Lumpur

Members (in alphabetical order)

Dr. Azza Omar
Respiratory Physician
Hospital Raja Perempuan Zainab II,
Kelantan

Dr. Mazapuspavina Md. Yasin
Family Medicine Specialist
Universiti Teknologi Mara, Selangor

Ms. Chong Li Yin
Pharmacist
Hospital Serdang, Selangor

Dr. Mohd. Aminuddin Mohd. Yusof
Head, Clinical Practices Guidelines Unit
Health Technology Assessment Section
(MaHTAS), Ministry of Health, Putrajaya

Dr. Hilmi Lockman
Consultant Respiratory Physician
Prince Court Medical Centre,
Kuala Lumpur

Dr. Mohd. Arif Mohd. Zim
Consultant Respiratory Physician
Universiti Teknologi Mara, Selangor

Dr. Ida Zaliza Zainol Abidin
Emergency Physician
Hospital Tuanku Fauziah, Perlis

Dr. Nor Azila Mohd. Isa
Family Medicine Specialist
Klinik Kesihatan Telok Datok, Selangor

Dr. Irfhan Ali Hyder Ali
Consultant Respiratory Physician
Hospital Pulau Pinang, Pulau Pinang

Dr. Shamsuriani Md. Jamal
Emergency Physician
Pusat Perubatan Universiti Kebangsaan
Malaysia, Kuala Lumpur

Mr. Jaya Muneswarao A/L Ramadoo@
Devudu
Pharmacist
Hospital Kulim, Kedah

Dr. Yoon Chee Kin
General Physician
Hospital Pulau Pinang, Pulau Pinang

Dr. Leong Swee Wei
General Physician
Hospital Serdang, Selangor

Dr. Zul Imran Malek Abdol Hamid
Emergency Physician
Hospital Pakar Sultanah Fatimah, Johor

REVIEW COMMITTEE

The draft guidelines were reviewed by a panel of experts from both public and private sectors. They were asked to comment primarily on the comprehensiveness and accuracy of the interpretation of evidence supporting the recommendations in the guidelines.

Chairperson

Dr. Jamalul Azizi Abdul Rahaman
Senior Consultant Pulmonologist
Hospital Serdang, Selangor

Members

Dr. G.R. Letchuman Ramanathan
Senior Consultant General Physician
Hospital Raja Permaisuri Bainun, Perak

Dr. Iskandar Firzada Osman
Consultant Family Medicine Specialist
Klinik Kesihatan Jaya Gading, Pahang

Dr. Junainah Sabirin
Deputy Director
Health Technology Assessment Section (MaHTAS)
Ministry of Health, Putrajaya

Dr. Raja Salihatunnisa Raja Ibrahim
Patient Advocate
Kelantan

Dr. Roslan Harun
Consultant Respiratory Physician
KPJ Ampang Puteri Specialist Hospital, Kuala Lumpur

Professor Dr. Roslina Abdul Manap
Senior Consultant Respiratory Physician
Pusat Perubatan Universiti Kebangsaan Malaysia

Dr. Sabariah Faizah Jamaluddin
Senior Consultant Emergency Physician
Hospital Sungai Buloh, Selangor

Ms. Suhadah Ahad
Pharmacist
Hospital Melaka, Melaka

EXTERNAL REVIEWERS (in alphabetical order)

The following external reviewers provided feedback on the draft:

Professor Dato' Dr. Hj. Abdul Razak Muttalif
Senior Consultant Chest Physician & Professor and Head of Medicine
MAHSA University, Kuala Lumpur

Professor Dr. Nik Hisamuddin Nik Abdul Rahman
Head of Department & Consultant Emergency Physician
Hospital Universiti Sains Malaysia, Kelantan

Associate Professor Dr. Bandana Saini
Senior Lecturer
The University of Sydney, Australia

Associate Professor Dr. Pang Yong Kek
Consultant Respiratory Physician,
Pusat Perubatan Universiti Malaya,
Kuala Lumpur &
President, Malaysian Thoracic Society

Associate Professor Dr. Baharudin Ibrahim
Chairman of Clinical, Social & Administrative Pharmacy
Universiti Sains Malaysia

Professor Dr. Richard Beasley
Consultant Respiratory Physician,
University of Otago, New Zealand &
Director, Medical Research Institute of New Zealand

Dr. Chuah Siew Kee
Consultant General Physician
Pantai Specialist Hospital, Selangor

Dr. Siti Suhaila Mohd Yusoff
Family Medicine Specialist
Universiti Sains Malaysia, Kelantan

Professor Dr. David Price
Professor of Primary Care Respiratory Medicine
University of Aberdeen, United Kingdom

Dr. Sri Wahyu Taher
Consultant Family Medicine Specialist & Head of Clinic
Klinik Kesihatan Simpang Kuala, Kedah

Dr. Faheem Ahmed Khan
Consultant Emergency Medicine & Intensive Care Medicine
Ng Teng Fong General Hospital (NUHS Group), Singapore

Datuk Dr. Tarmizi Thayaparan
Group Medical Director & Consultant Physician
Mawar Medical Centre, Negeri Sembilan

Professor Dato' Seri Dr. K. Sree Raman
Senior Consultant Physician
Perdana University RCSI, Selangor

Professor Dr. Tong Seng Fah
Consultant Family Medicine Specialist
Pusat Perubatan Universiti Kebangsaan Malaysia, Kuala Lumpur

Professor Dr. Mohammed Fauzi Abdul Rani
Senior Consultant Respiratory Physician
Universiti Teknologi Mara, Sg. Buloh Campus, Selangor

Dato' Dr. Zainudin Md. Zin
Consultant Physician, Internal & Respiratory Medicine
KPJ Damansara Specialist Hospital
Selangor

ALGORITHM 1. STEPWISE TREATMENT LADDER IN STABLE ASTHMA

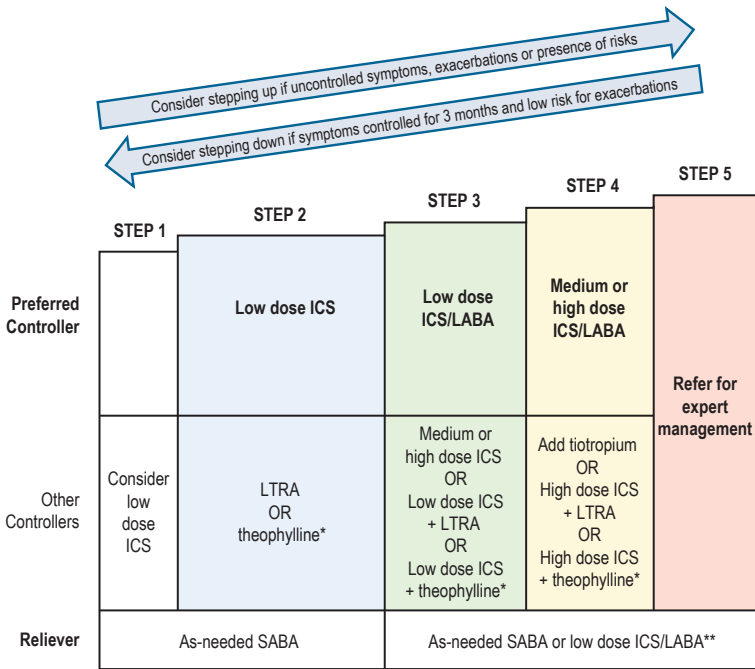

ICS = inhaled corticosteroids, LABA = long-acting β_2 -agonists, ICS/LABA = combination medication in a single inhaler,

LTRA = leukotriene receptor antagonists, SABA = short-acting β_2 agonists, *theophylline= ≤ 250 mg daily

**Budesonide/formoterol or beclometasone/formoterol

Patients who are steroid-naïve presenting at Step 3 and 4, should be initiated on low dose ICS

BEFORE CONSIDERING STEP UP, CHECK INHALER TECHNIQUE AND TREATMENT ADHERENCE.

Modified: Global Initiative for Asthma. Global Strategy for Asthma Management and Prevention, 2017 (Available at www.ginasthma.org)

ALGORITHM 2. MANAGEMENT OF ACUTE EXACERBATION OF ASTHMA IN PRIMARY CARE

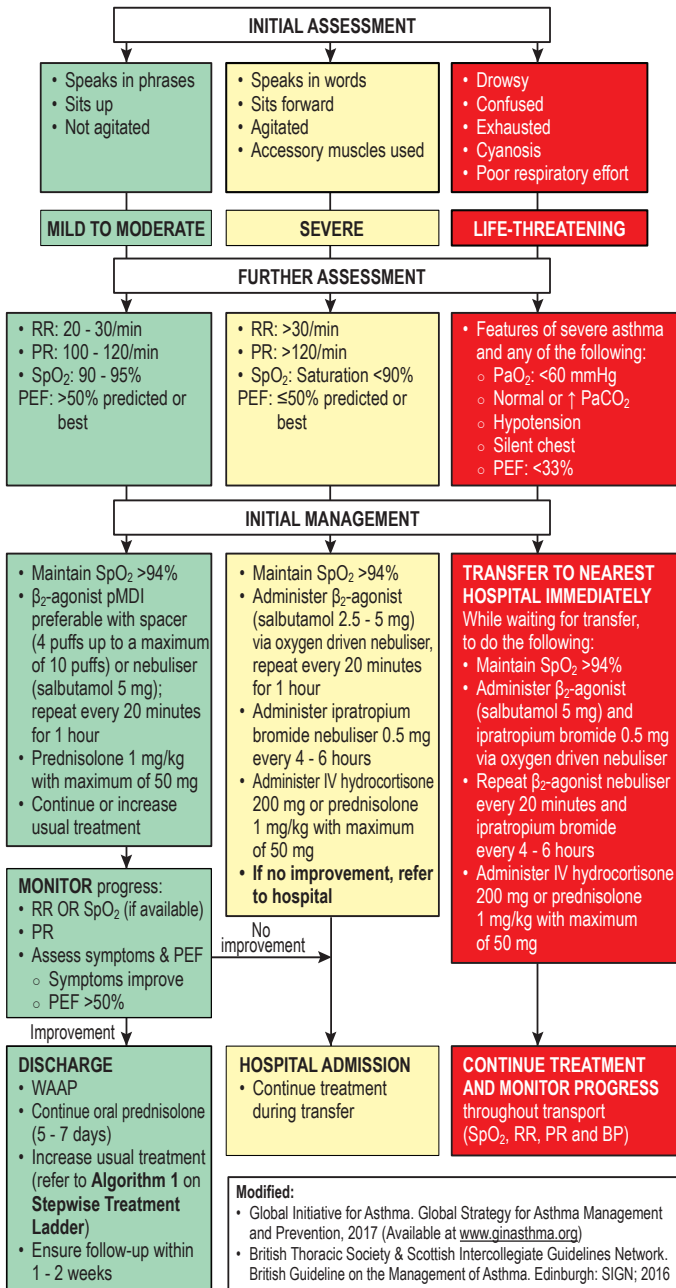

ALGORITHM 3. MANAGEMENT OF ACUTE EXACERBATION OF ASTHMA IN EMERGENCY DEPARTMENT

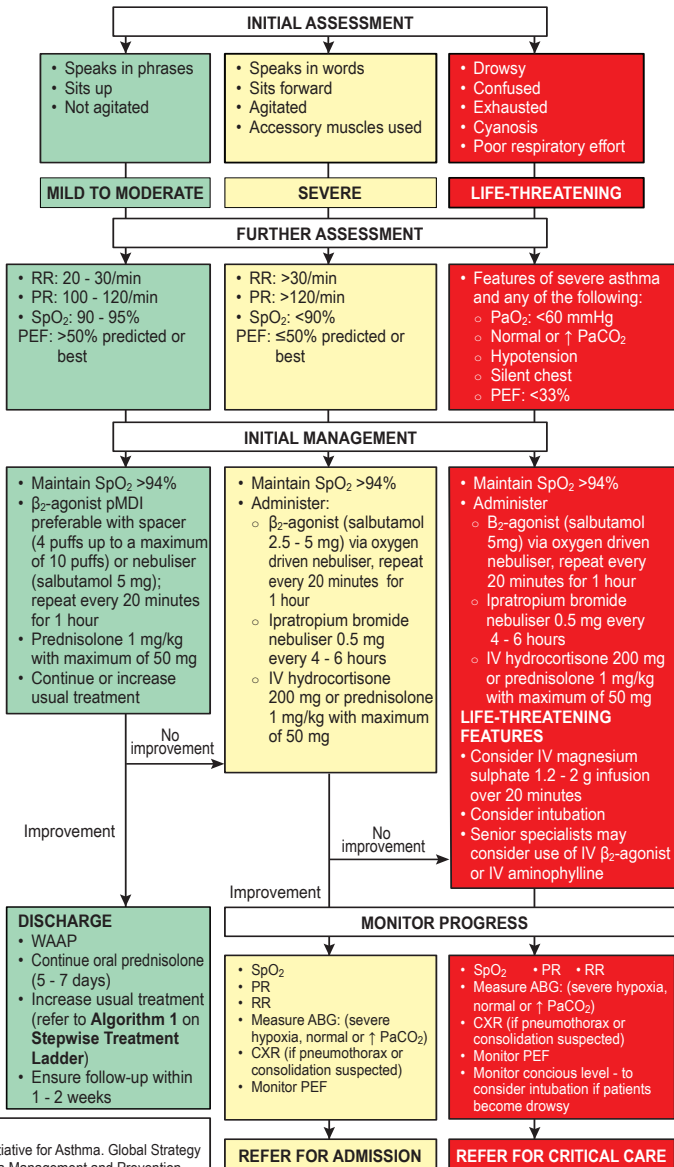

Modified:

- Global Initiative for Asthma. Global Strategy for Asthma Management and Prevention, 2017 (Available at www.ginasthma.org)
- British Thoracic Society & Scottish Intercollegiate Guidelines Network. British Guideline on the Management of Asthma. Edinburgh: SIGN; 2016

1. INTRODUCTION

Asthma is a common medical condition seen at all levels of health care in Malaysia. It is associated with increased morbidity and mortality. Asthma is an inflammatory disease of the airways triggered by external stimuli in genetically-predisposed individuals. This leads to mucus secretion, bronchoconstriction and airway narrowing.

The most common symptom of asthma is chronic cough. Due to the absence of typical wheezing and marked breathlessness in some patients, asthma is frequently misdiagnosed or underdiagnosed. This causes persistent airway inflammation, airway remodelling and subsequently fixed airway obstruction over time. It is important for healthcare professionals to confidently diagnose and manage asthma.

The first Malaysian CPG for management of adult asthma was a consensus guideline by the Malaysian Thoracic Society (MTS) in 1996. The revised edition in 2002 used evidence-based principle and published as a joint statement of the MTS, MoH Malaysia and Academy of Medicine Malaysia. Since then, there have been many developments and publications with regards to the assessment tools, pharmacotherapy, inhaler devices and treatment modalities that necessitate the revision of the CPG. This edition is the first evidence-based CPG developed using systematic review methodology and the scope expanded/added on risk factors, diagnosis, self-management, treatment on both stable and acute exacerbation of asthma, special groups and referral.

Local guidelines provide practical tools to facilitate diagnosis and assessment of asthma. This CPG is aimed at delivering evidence-based statements and recommendations to all healthcare professionals which would lead to standardised and improved management of asthma in Malaysia.

2. EPIDEMIOLOGY AND RISK FACTORS

2.1 Epidemiology

Asthma is a common chronic disease worldwide. The global prevalence of clinical asthma (or treated asthma) was 4.5% (95% CI 4.4 to 4.6) in 2002. The prevalence of clinical asthma varies from 1.0% in Vietnam to 21.5% in Australia.^{1, level III}

In Malaysia, the prevalence of asthma in adults (18 years and above) was 4.5% based on the National Health and Morbidity Survey 2006. Of this, follow-up rate in clinics and hospitals was only 32.6%. Exacerbation

rate was 68.1% (CI 65.5 to 70.6) of which 25.8% (CI 23.1 to 28.7) were >3 exacerbations in a year.^{2, level III}

2.2 Risk Factors

Asthma is a multifactorial disease brought about by various familial and environmental influences.

2.2.1 Genetic factors

In a large multinational study, the risk of developing asthma in offspring was significantly higher in those with both parents having asthma compared with only a single parent having the disease. The risk was 2.9 (95% CI 2.4 to 3.5) if a father had asthma and 3.2 (95% CI 2.6 to 3.9) if the mother had asthma. The risk increased to 7.0 (95% CI 3.9 to 12.7) if both parents were affected.^{3, level III}

2.2.2 Environmental factors

a. Smoking

Smoking is associated with a higher risk for adult-onset asthma compared with non-smoking (HR=1.95, 95% CI 1.00 to 3.77).^{4, level II-2}

b. Air pollution

An European study showed a significant increase in number of cases of asthma attacks attributed to outdoor and traffic-related air pollution exposure.^{5, level II-2} A systematic review on observational studies showed that pollutants such as nitrous oxide, particulate matter size <2.5 µm, carbon monoxide and ozone had significant association with asthma exacerbations.^{6, level II-2}

c. Paint

Exposure to inhaled substances such as conventional paint, propylene glycol, water-based paint glycol/glycol ethers with and without ammonia has been shown to provoke allergic reactions or irritate the airways. Non-spray paints significantly increase the risk of bronchial hyperreactivity, asthma symptoms or medication use while outdoor paints increases cough and wheeze in asthmatics. Homes that have been painted during the past year are associated with an increased prevalence of nocturnal breathlessness and current asthma.^{7, level I}

d. Pesticides

A systematic review showed a significant association between exposure to insecticides with asthma symptoms and exacerbations. A number of allergens including pesticides were significantly associated with adult-onset asthma.^{8, level II-2}

2.2.3 Other risk factors/co-morbidities

a. Overweight and obesity

The incidence of asthma is associated with overweight/obesity (OR=1.51, 95% CI 1.27 to 1.80). The association is weight-dependent. Compared with normal weight, the OR for 1-year asthma incidence in:^{9, level II-2}

- i. overweight is 1.38 (95% CI 1.17 to 1.62)
- ii. obese is 1.92 (95% CI 1.43 to 2.95)

b. Gastro esophageal reflux disease

A systematic review showed significant association between gastro esophageal reflux disease (GERD) and asthma.^{10, level II-2}

c. Nasal blockage, rhinorrhoea and allergic rhinitis

Nasal blockage and rhinorrhoea are significantly increased in those with multi-symptom asthma vs fewer-symptom asthma with ORs of 2.21 (95% CI 1.64 to 2.97) and 1.49 (95% CI 1.10 to 2.02) respectively. The prevalence of allergic rhinitis is also significantly higher in this group. Multi-symptom asthma refers to:^{11, level III}

- physician-diagnosed asthma
- use of asthma medication
- attacks of shortness of breath and recurrent wheeze, and at least one of the following:
 - wheeze
 - dyspnoea
 - dyspnoea on exertion/exposure to cold

d. Fractional exhaled nitric oxide and skin prick test

A local cross-sectional study among office workers showed that the presence of combined elevated fractional exhaled nitric oxide (FeNO) and atopic subjects (positive skin prick test) was significantly associated with doctor-diagnosed asthma, rhinitis and airway symptoms.^{12, level III}

- The identification of risk factors is important in the management of asthma.

3. DIAGNOSIS

There is no gold standard diagnostic clinical test in diagnosing asthma. Asthma diagnosis is based on a combination of:

- History
 - wheeze
 - cough
 - chest tightness
 - shortness of breath
- Presence of obstructive airflow reversibility

It is essential to take a detailed history and pay particular attention to symptom variability as well as presence of airflow obstruction in clinical examination. A response to treatment (bronchodilator or corticosteroids) may aid the diagnosis but a lack of response may not exclude asthma.

Pattern of symptoms typical of asthma

Common symptoms	Wheeze Cough Chest tightness Shortness of breath
Symptom variability	Episodic symptoms Diurnal symptoms Symptoms after/during exercise
Triggers	Common colds (viral infection) Allergens e.g. house dust mite, pets Cold weather Irritants <ul style="list-style-type: none"> • smoke • haze • strong smells i.e. perfumes, cleaning solutions • exhaust fumes
History of atopy	Eczema Allergic rhinitis
Family history of atopy	Asthma Allergic rhinitis Eczema

Physical examination

General examination	Eczema
Respiratory examination	Use of accessory muscles Hyperinflation Audible wheeze Rhonchi on auscultation

Low probability of asthma

- Isolated cough
- Chronic sputum production
- Chest pain
- Absence of wheeze when dyspnoeic
- Symptoms beginning later in life
- Chronic smoker [chronic obstructive pulmonary disease (COPD)] needs to be considered as a diagnosis

Clinical tests for asthma

- In asthma, spirometry is the investigation of choice and more reliable than peak expiratory flow.¹³ This should be carried out by trained personnel, using well-maintained and calibrated equipment.

Table 1 below shows different investigations that may be performed for the diagnosis of asthma.

Table 1. Investigations for Asthma

Investigation	Description
Demonstration of airway obstruction	
Spirometry	<ul style="list-style-type: none"> • A FEV1 (forced expiratory volume in 1 second)/FVC (forced vital capacity) ratio of <70% is a positive test for obstructive airway disease
Demonstration of airway obstruction variability	
Bronchodilator reversibility	<ul style="list-style-type: none"> • An improvement in FEV1 of $\geq 12\%$ AND ≥ 200 ml is a positive bronchodilator reversibility test
Other method	<ul style="list-style-type: none"> • An increase in FEV1 $>12\%$ and >200 ml (or PEF $>20\%$) from baseline after four weeks on inhaled corticosteroid (ICS) is a positive test. Patient must not have respiratory infections.
Peak flow charting	<ul style="list-style-type: none"> • Peak flow monitoring over 2 - 4 weeks • Calculate mean variability. Daily diurnal PEF variability is calculated from twice daily PEF as [(day's highest - day's lowest)/mean of day's highest and lowest] and average over one week. • Variability $\geq 20\%$ or diurnal variation $>15\%$ on >3 days/week indicates a positive test
Challenge tests (not routinely performed in clinical practice)	Methacholine challenge <ul style="list-style-type: none"> • A PC₂₀ value of ≤ 8 mg/ml is a positive test
	Mannitol challenge <ul style="list-style-type: none"> • Fall in FEV1 of $\geq 15\%$ at cumulative dose of ≤ 635 mg is a positive test
	Exercise challenge (refer to Section 9.3)
Detection of eosinophilic inflammation or atopy	
Blood eosinophils	<ul style="list-style-type: none"> • Threshold for blood eosinophils is $>4.0\%$
IgE	<ul style="list-style-type: none"> • Any allergen-specific IgE >0.35 kU/L in adults • Total IgE in adults >100 kU/L
FeNO	<ul style="list-style-type: none"> • A level of ≥ 40 ppb is a positive test

Modified:

1. British Thoracic Society & Scottish Intercollegiate Guidelines Network. British Guideline on the Management of Asthma. Edinburgh: SIGN; 2016
2. Global Initiative for Asthma. Global Strategy for Asthma Management and Prevention, 2017. (Available at www.ginasthma.org)

Refer to **Appendix 3** on **Peak Expiratory Flow Rate Variability** and **Appendix 4** on **Peak Expiratory Flow Nomogram**.

Recommendation 1

- Diagnosis of asthma should be made based on typical clinical history and supported by positive obstructive airflow reversibility with spirometry. The higher the reversibility (or peak flow variability), the higher the probability of asthma.

4. GENERAL PRINCIPLES OF MANAGEMENT

Asthma management should be aimed at achieving good asthma symptom control and minimising future risk of exacerbations. These goals should be communicated with the patients/carers throughout the treatment process. Patients/carers should be informed of the potential side effects of asthma medications used.

When a drug is prescribed, patient's preferences, the ability of using the inhaler correctly and cost of medication should all be taken into consideration. The partnership between the patients/carers and the healthcare providers including the pharmacists and nurses is important in ensuring the success of the management.

5. ASTHMA SELF-MANAGEMENT

Asthma is a chronic disease that requires patient's involvement in its management. This includes education and skills to effectively manage their asthma in partnership with their healthcare providers.

- The components of asthma self-management include:
 - self-monitoring of symptoms and/or PEF
 - written asthma action plan (WAAP)
 - regular medical review by healthcare providers

5.1 Role of Self-management

Self-monitoring by either PEF or symptoms with regular medical review and a WAAP reduces emergency hospital visits (RR=0.82, 95% CI 0.73 to 0.94) and hospitalisation rates (RR=0.64, 95% CI 0.50 to 0.82) compared with usual care in asthma.^{14, level I}

Optimisation of asthma control by adjustment of medications may be conducted by either self-adjustment with the aid of a WAAP or by regular medical review. There is no difference between the two methods in hospitalisation, emergency department (ED) visit, unscheduled doctor visit and nocturnal asthma. Individualised WAAP based on PEF is equivalent to the plan based on symptoms in hospitalisation and ED room visit.^{15, level I}

The use of limited asthma education (without self-monitoring, modifications of medical therapy or usage of individualised action plans) does not improve health outcomes in adults with asthma although patient's perceived symptoms may improve.^{16, level I}

Educational interventions applied in ED reduce subsequent asthma hospital admissions (RR=0.50, 95% CI 0.27 to 0.91) but does not reduce ED re-presentations (RR=0.66, 95% CI 0.41 to 1.07).^{17, level I}

- Home nebuliser should be avoided as it leads to underestimation of the severity of an acute exacerbation of asthma.

5.2 Written Asthma Action Plan

WAAP contains action (decision) points which guide patients in making short-term adjustments to their treatment based on their symptoms and/or PEF. Refer to **Appendix 5 on Written Asthma Action Plan**.

An effective WAAP may contain two to four action points. In PEF-based plans, personal best PEF should be used for the action point. The treatment instruction should include reliever therapy, ICS and oral corticosteroids (OCS).^{18, level I}

Current evidence does not support increasing (doubling) the dose of ICS as part of WAAP to treat exacerbations in mild to moderate asthma.^{19, level I} Patients are advised to seek further medical assistance if symptoms persist despite following the WAAP. The attending physician may choose to increase the ICS dose upon review.

Patients on combination of ICS/long-acting β_2 -agonists (LABA i.e. budesonide/formoterol or beclometasone/formoterol) in a single inhaler as both maintenance and reliever therapy should continue their maintenance ICS/LABA and increase their reliever ICS/LABA as needed. Clear instructions on usage and maximum doses should be written in the WAAP.

Recommendation 2

- All asthma patients should be offered self-management education.
 - Written asthma action plan (WAAP) is the preferred option.
- WAAP should be based on symptoms and/or peak expiratory flow readings.

5.3 Education Modality

- Patient education is defined as a planned learning experience using a combination of teaching, counselling and behaviour modification techniques. This is an interactive process to improve patient's knowledge and health behaviour.

Asthma education can be delivered by healthcare providers including pharmacists and nurses.

Pharmacist-delivered asthma care programme improves:

- asthma control (OR=2.68, 95% CI 1.64 to 4.37) and adherence to preventer medication (OR=1.89, 95% CI 1.08 to 3.30).^{20, level I}
- Asthma Control Test (ACT) score (MD=2.0, 95% CI 0.1 to 3.9), reliever medication use (MD= -0.34, 95% CI -0.60 to -0.08), frequency of night-time awakenings (MD= -3.5, 95% CI -7.0 to -0.1), inhalation technique (MD=11.0, 95% CI 1.0 to 21.1) and adherence to medications (MD=15.7, 95% CI 3.0 to 28.4).^{21, level I} Refer

Appendix 6 on Asthma Control Test.

- A local randomised control trial (RCT) conducted in health clinics showed that Pharmacy Management Service which focused on medication adherence, correct inhaler technique and provision of adequate knowledge on asthma resulted in significant improvement of asthma control.^{22, level I}

In Malaysia, the Respiratory Medication Therapy Adherence Clinic has been conducted by pharmacists in collaboration with other healthcare providers in managing asthma by providing education, monitoring adherence and resolving medication-related problems.^{23, level III}

Nurse educators can play a role in asthma management. Trained nurses working as educators and coordinators in management of asthma in community based clinics have demonstrated positive impact on patient outcomes.^{24, level I}

The use of Chronic Care Model (CCM), as a framework for the design and implementation of interventions, improves adherence to ICS in asthma. The inclusion of a greater number of CCM components within interventions is significantly associated with stronger effects on ICS adherence.^{25, level I}

A shared decision model between patient and healthcare providers, based on treatment goals and patient's preferences, improves asthma care management.^{26, level I}

Recommendation 3

- Health education on asthma should be provided by all healthcare providers including pharmacists and allied health professionals.

6. STABLE ASTHMA

A patient is said to have stable asthma when there are absence of symptoms, no limitations of activities and no use of reliever medication in the last four weeks. Alternatively, stable asthma is classified when the ACT scores are 20 - 25.¹³ Asthma control can be assessed either by asking questions recommended by Global Initiative for Asthma/GINA (refer to **Table 2**)¹³ or British Thoracic Society & Scottish Intercollegiate Guidelines Network (refer to **Table 3**).²⁷

Table 2. Assessment of asthma symptom control¹³

Asthma symptom control			Level of asthma symptom control		
In the past four weeks, has the patient had:			Well controlled	Partly controlled	Uncontrolled
• Daytime asthma symptoms more than twice/week?	Yes <input type="checkbox"/>	No <input type="checkbox"/>	None of these	1 - 2 of these	3 - 4 of these
• Any night waking due to asthma?	Yes <input type="checkbox"/>	No <input type="checkbox"/>			
• Reliever needed for symptoms more than twice/week	Yes <input type="checkbox"/>	No <input type="checkbox"/>			
• Any activity limitation due to asthma?	Yes <input type="checkbox"/>	No <input type="checkbox"/>			

Table 3. UK Royal College of Physicians' '3 Questions' screening tool²⁷

Methodology	Measurement characteristics	Comments
<p>Yes/no or graded response to the following three questions:</p> <p>In the last week (or month)</p> <ol style="list-style-type: none"> 1. Have you had difficulty sleeping because of your asthma symptoms (including cough)? 2. Have you had your usual asthma symptoms during the day (cough, wheeze, chest tightness or breathlessness)? 3. Has your asthma interfered with your usual activities (e.g. housework, work/school, etc.)? 	No to all questions consistent with controlled asthma	<p>Not well validated in adults</p> <p>Simplicity is attractive for use in day-to-day clinical practice</p>

6.1 Assessment of Severity for Future Risk

Asthma patients should be regularly followed-up to assess asthma control and adjust treatment accordingly. The following factors should be monitored and recorded during follow-up:

- assessment of asthma control
- asthma attacks
- frequency of bronchodilator use
- use of OCS and absence from work/school since last follow-up
- inhaler technique and adherence (refer to **Appendix 8 on Inhaler Devices and Techniques**)
- lung function assessment by spirometry or PEF
- use of a self-management plan/personal action plan

This involves adjustment of treatment and review of responses as shown in **Figure 1**.

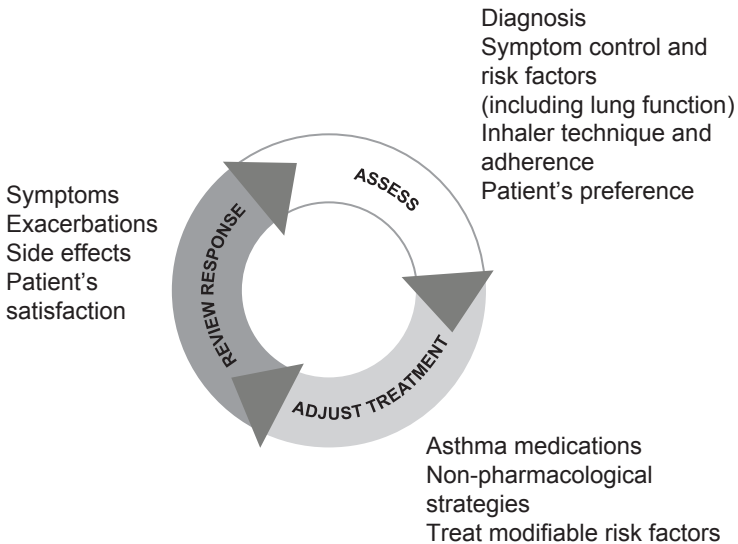

Figure 1. The control-based asthma management cycle

Modified: Global Initiative for Asthma. Global Strategy for Asthma Management and Prevention, 2017. (Available at www.ginasthma.org)

Assessment of asthma control has two domains which are symptom control (refer to **Table 2** and **3**) and risk factors for future outcomes (refer to **Table 4**). Refer to **Appendix 8** on **Inhaler Devices and Techniques**.

Table 4. Assessment of risk factors for poor asthma outcomes¹³

Risk factors for poor asthma outcomes	
<ul style="list-style-type: none"> • Assess risk factors at diagnosis and periodically, at least every 1 - 2 years, particularly for patients experiencing exacerbations. • Measure FEV1 at start of treatment, after 3 - 6 months of controller treatment to record patient's personal best lung function, then periodically for ongoing risk assessment. 	
<ul style="list-style-type: none"> • Potentially modifiable independent risk factors for exacerbations include: <ul style="list-style-type: none"> ○ Uncontrolled asthma symptoms (refer to Table 2 or Table 3) ○ ICS not prescribed, poor ICS adherence, incorrect inhaler technique (refer to Appendix 8 on Inhaler Devices and Techniques) ○ High short-acting β_2-agonists (SABA) use (with increased mortality if $>1 \times 200$-dose canister/month) ○ Low FEV1, especially if $<60\%$ predicted ○ Major psychological or socioeconomic problems ○ Exposures: smoking; allergen exposure if sensitised ○ Co-morbidities: obesity, rhinosinusitis, confirmed food allergy ○ Sputum or blood eosinophilia, elevated FeNO in allergic adults ○ Pregnancy • Other major independent risk factors for exacerbations include: <ul style="list-style-type: none"> ○ Ever being intubated or in intensive care for asthma ○ Having ≥ 1 severe exacerbations in the last 12 months 	<p>Having one or more of these risk factors increase the risk of exacerbations even if symptoms are well controlled</p>
<ul style="list-style-type: none"> • Risk factors for developing fixed airflow limitation include lack of ICS treatment, exposure to tobacco smoke, noxious chemicals or occupational exposures, low FEV1, chronic mucus hypersecretion and sputum or blood eosinophilia. 	
<ul style="list-style-type: none"> • Risk factors for medication side effects include: <ul style="list-style-type: none"> ○ Systemic: frequent OCS, long-term high dose ICS, also taking P450 inhibitors e.g. itraconazole, ketoconazole, etc. ○ Local: high dose or potent ICS, poor inhaler technique (refer to Appendix 8 on Inhaler Devices and Techniques) 	

Patient's scheduled visits are suggested as follows:

- within 1 - 2 weeks after an exacerbation
- 1 - 3 months after starting treatment
- every 3 - 6 months once stable
- every 4 - 6 weeks in pregnancy

6.2 Criteria for Step Up/Step Down

When asthma is not controlled based on symptom control and increased future risk (refer **Table 2** and **Table 4**), assess the following common issues first before consider stepping up treatment:

- Incorrect inhaler technique (refer to **Appendix 8** on **Inhaler Devices and Techniques**)
- Poor adherence to medications
- Modifiable risk factors
- Symptoms due to co-morbid conditions e.g. allergic rhinitis

There are 3 ways of doing it:

1. Sustained step up (at least 2 - 3 months) if symptoms and/or exacerbations persist despite 2-3 months of controller treatment
2. Short term step up (for 1 - 2 weeks) with WAAP e.g. during viral infection or allergen exposure
3. Day-to-day adjustment by patient for those prescribed single inhaler therapy for maintenance and reliever

Consider stepping down treatment once good asthma control has been achieved and maintained for three months. The aim is to find the lowest treatment dose for asthma control and minimise side effects. Choose an appropriate time for step down (e.g. no respiratory infection, not travelling, not pregnant, etc.).

Step down by reducing the ICS dose by 25 - 50% at 2 - 3 month intervals. Exercise caution before withdrawing ICS completely for patients on long-term treatment especially those with history of severe exacerbations. Do not withdraw ICS abruptly. Make sure a follow-up appointment is arranged.

Recommendation 4

- Inhaler technique and adherence to treatment should be assessed at every clinic visit and before escalating treatment in the management of asthma.

6.3 Treatment

This treatment section is written based on GINA guidelines¹³ and new evidence modified to suit local setting.

The goal of asthma treatment is to achieve and maintain symptom control. This is done in a stepwise approach as shown in **Figure 2**. Asthma medications consist of relievers and controllers. Relievers are medications taken to relieve symptoms of wheeze and breathlessness. Controllers are medications taken regularly to prevent exacerbations and control symptoms. Refer to **Appendix 7** on **Common Medications in Asthma** and **Appendix 8** on **Inhaler Devices and Techniques**.

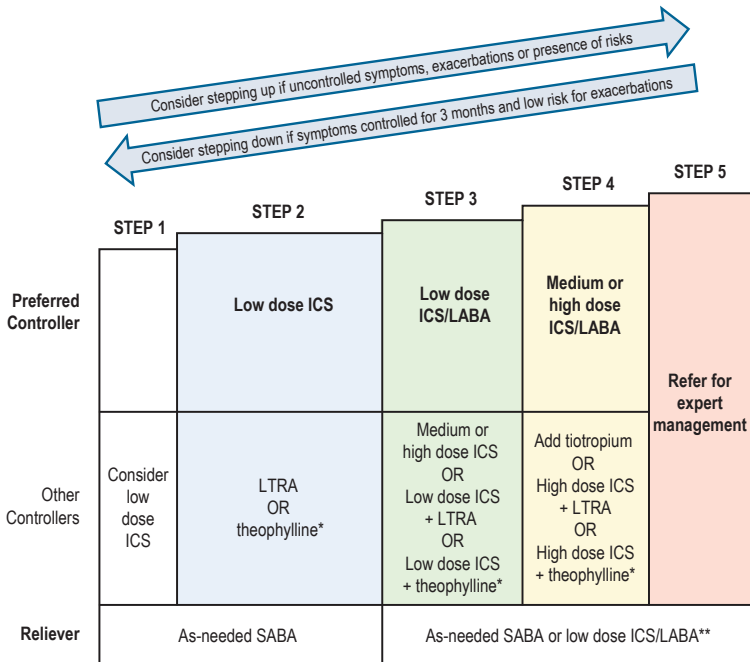

ICS = inhaled corticosteroids, LABA = long-acting β_2 -agonists, ICS/LABA = combination medication in a single inhaler, LTRA = leukotriene receptor antagonists, SABA = short-acting β_2 agonists, *theophylline = ≤ 250 mg daily

**Budesonide/formoterol and beclometasone/formoterol

Patients who are steroid-naïve presenting at Step 3 and 4, should be initiated on low dose ICS

Figure 2. Stepwise Treatment Ladder in Stable Asthma

Modified: Global Initiative for Asthma. Global Strategy for Asthma Management and Prevention, 2017. (Available at www.ginasthma.org)

Larger **Figure 2** is shown in **Algorithm 1**.

- Asthma treatment can be adjusted according to the severity of disease and symptom control based on **Figure 2**. The treatment may start at any step of the ladder depending on the symptom control. It may be stepped-up if needed and stepped-down once symptoms are controlled.
- Before considering step up, check inhaler technique and treatment adherence. Refer to **Appendix 8 on Inhaler Devices and Techniques**.

Existing guidelines recommend the use of spacer with pressurised metered-dose inhaler (pMDI) to improve delivery and reduce potential side effects.^{13; 27}

- Patients who are unable to use pMDI correctly should be prescribed spacer, preferably valved holding chambers.

6.3.1 As-needed reliever therapy

a. Short-acting β_2 -agonists

SABA are effective as an immediate symptom reliever in asthma.^{13; 27} However, regular use of SABA alone without ICS worsens lung function significantly and increases airway inflammation in asthma.^{28, level I}

There is no added benefit in using combination of short-acting muscarinic antagonists (SAMA) and SABA vs SABA alone in symptom scores and peak flow rates in chronic asthma.^{29, level I}

Oral SABA has a slower onset of action and higher risk of side-effects compared with inhaled SABA.¹³

b. Combined low dose inhaled corticosteroids/long-acting β_2 -agonists (single inhaler therapy for maintenance and reliever therapy)

Combined low dose ICS/LABA as a single inhaler for maintenance and reliever therapy significantly reduces severe exacerbations in moderate to severe asthma compared with fixed dose ICS/LABA (equivalent or higher dose of ICS component) with an additional as-needed SABA. There is no difference in serious adverse events between the treatment regimens.^{30 - 31, level I} In a real-life practice setting among Malaysian patients, single inhaler for maintenance and reliever therapy significantly achieved better asthma control and greater patient satisfaction compared with previous conventional asthma regimes.^{32, level II-3} Currently only budesonide/formoterol and beclometasone/formoterol are licensed for this indication.

c. Long-acting β_2 -agonist

The rapid-onset LABA i.e. formoterol is as effective as SABA as a reliever medication in asthma, but its use without ICS is strongly discouraged because of the risk of fatal and non-fatal adverse events.^{33, level I}

Recommendations 5

- Inhaled short-acting β_2 -agonists (SABA) are the reliever of choice in stable asthma.
- Oral SABA should be avoided in asthma due to their side effects.
- Low dose of budesonide/formoterol or beclometasone/formoterol may be used as a single inhaler for maintenance and reliever therapy in moderate to severe asthma.
- Inhaled long-acting β_2 -agonists without inhaled corticosteroids should not be used as reliever monotherapy in stable asthma.

6.3.2 Controller therapy (in addition to as-needed reliever inhaler)

Controller medication should be adjusted in a stepwise approach to achieve good asthma control. This will minimise future risk of exacerbation, and improve airflow limitation. Treatment may be stepped down after 2 - 3 months of good asthma control.

Before considering any step up of treatment in a patient with persistent symptoms and/or exacerbation, the following need to be assessed:

Steps before initial controller treatment

- Confirm the diagnosis of asthma, if possible.
- Document symptom control (e.g. ACT score).
- Identify possible risk factors and co-morbidities.
- Perform lung function test (e.g. PEF and/or spirometry with reversibility).
- Discuss with patient on treatment preference and cost.
- Ensure correct use of inhalers.
- Plan appropriate follow-up visit.

Steps after initial controller treatment

- Review patient's response to treatment after 2 to 3 months or earlier if clinically indicated.
- Refer to **Figure 2** for stepwise approach to treatment.

a. Step 1**Preferred option: As-needed reliever therapy**

- Patients with initial presentation of the following conditions are considered to be managed in **Step 1**:
 - asthma symptoms **OR** need for SABA (less than twice a month)
AND
 - no waking up at night due to asthma in last month
AND
 - no risk factors for exacerbations including no exacerbation in the last year

Other controller options:

In Step 1, controller is generally not required. However, in patients at risk of exacerbations (refer to **Table 4**), starting low dose ICS (refer to **Table 5**) significantly reduces the risk for first severe asthma exacerbation and rate of poorly controlled asthma days.^{34 - 35, level I} Thus, these patients should be considered for low dose ICS therapy.

b. Step 2**Preferred option: Low dose ICS**

- The patients with initial presentation of the following conditions are considered to be managed in **Step 2**:
 - asthma symptoms or need for SABA between twice a month and twice a week
OR
 - wakes up at night due to asthma once or more a month
 - with no risk factors in **Table 4**
- For patients who **remain symptomatic in Step 1**, treatment should be **escalated to Step 2**.

Starting low dose ICS in symptomatic corticosteroid-free patients significantly improves time to the first severe asthma exacerbation, exacerbation rate, asthma symptoms, nocturnal awakening and number of rescue inhaler use.^{34 - 35, level I}

Other controller options:

Other controller options may be considered in patients who are unable to tolerate ICS.¹³ Leukotriene receptor antagonists (LTRA)^{36, level I} and theophylline^{37, level I} are less effective than ICS as monotherapy in terms of symptom control as well as lung function improvement. There is no difference in adverse events between LTRA and ICS.^{36, level I}

c. Step 3**Preferred option: Low dose ICS/LABA**

- The patients with initial presentation of the following conditions are considered to be managed in **Step 3**:
 - troublesome asthma symptoms more than twice a week
 - OR**
 - wakes up at night due to asthma once a week or more
 - AND**
 - with any risk factors in **Table 4**
- For patients who **remain symptomatic** in **Step 2**, treatment should be **escalated to Step 3**.

*However, patients who are steroid-naïve should be initiated on low dose ICS.

In asthma with sub-optimal control on low dose ICS monotherapy, combination of ICS/LABA is modestly more effective in reducing the risk of exacerbations than a higher dose of ICS alone (RR=0.88, 95% CI 0.78 to 0.98).^{38, level I}

Regular use of salmeterol monotherapy without an ICS in asthma causes significant increase in serious asthma-related events.^{33, level I} Adding inhaled salmeterol or formoterol to ICS therapy has shown no difference in asthma-related hospitalisation, intubation or death compared with ICS monotherapy.^{39 - 40, level I} Currently there are lack of data on the safety of other LABA as regular monotherapy.

ICS/LABA as maintenance and reliever therapy can be considered in **Step 3 and above**.

Other controller options:

If combination ICS/LABA in a single inhaler is not available, the following options can be used although less effective:^{41 - 42, level I}

- increase to moderate or high dose ICS
- add LTRA or theophylline to low dose ICS

Fewer adverse events are seen with LABA than theophylline.^{42, level I}

LTRA as add-on can be beneficial in patients with concomitant seasonal allergic rhinitis and asthma.^{43, level I}

d. Step 4**Preferred option: Medium/high dose ICS/LABA**

- Patients with initial presentation of the following conditions are considered to be managed in **Step 4**:
 - troublesome asthma symptoms more than twice a week
 - AND**
 - wakes up at night due to asthma once a week or more
 - AND**
 - with any risk factors in Table 4
 - OR**
 - acute exacerbation of asthma requiring hospital admission*
- For patients who **remain symptomatic** in **Step 3**, treatment should be **escalated to Step 4**.

*However, patients who are steroid-naïve should be initiated on low dose ICS.

Other controller options:

Soft mist inhaler tiotropium may be used as add-on therapy in patients with asthma not well controlled with medium or high dose ICS.^{44 - 45, level I} There is no strong evidence that tiotropium can substitute LABA as an add-on therapy to patients on ICS only.^{46, level I}

Sublingual allergen immunotherapy (SLIT) can be considered in patients with allergic rhinitis, sensitised to house dust mites, and exacerbation despite on low to high dose ICS, provided FEV1 is >70% predicted.¹³

e. Step 5**Preferred option: Referral to respiratory physician**

- Patients who are in **Step 4** with persistent symptoms and exacerbations despite good adherence to medications and inhaler technique should be referred to respiratory physician for further evaluation and treatment.

i. Tiotropium (Soft mist inhaler)

Tiotropium 5 µg daily soft mist inhaler as an add-on therapy in patients with symptomatic severe asthma despite being on medium or high dose ICS/LABA or step 4 treatment significantly improves lung function, reduces number of asthma exacerbations, increases the time to severe exacerbations and symptom control with fewer adverse events.^{44, level I; 47, level I}

- Tiotropium soft mist inhaler is only indicated as an add-on therapy on top of ICS/LABA after consultation with a specialist who is experienced in asthma management.

ii. Monoclonal antibodies

Two classes of monoclonal antibodies (anti-IgE and anti-interleukin-5) are currently licensed for poorly controlled asthma despite optimal use of medical therapy. Omalizumab is commonly used in Malaysia and it is a recombinant humanised monoclonal anti-IgE antibody that inhibits the binding of IgE to high-affinity receptors, thus reducing inflammatory response.

Omalizumab as an add on therapy is beneficial in moderate to severe asthma, uncontrolled with moderate to high doses of ICS with/without LABA which include:^{48, level I}

- reduction in exacerbations requiring oral steroids (OR=0.52, 95% CI 0.37 to 0.73)
- reduction in hospitalisation (OR 0.16, 95%CI 0.06 to 0.42)
- improvement in the Asthma Quality of Life Questionnaire/AQLQ (MD 0.31, 95%CI 0.23 to 0.39)
- reduction in use of β_2 -agonist medication [MD for moderate to severe asthma= -0.58 (95% CI -0.84 to -0.31) and MD for severe asthma -0.30, 95% CI -0.49 to -0.10]

There are fewer serious adverse events compared to standard care (OR 0.72, 95% CI 0.57 to 0.91)

Benefits after the discontinuation of omalizumab are observed up to 12 months. These include reduction of asthma medication (maintenance OCS and ICS therapy as well as the need for rescue therapy), exacerbation and hospitalisation.^{49, level III}

However, omalizumab use is limited due to its high cost.

Mepolizumab is an interleukin-5 antagonist monoclonal antibody (IgG1 kappa) indicated as an add-on maintenance treatment for patients with severe uncontrolled asthma aged 12 years and older, and with an eosinophilic phenotype. In severe eosinophilic asthma, subcutaneous mepolizumab leads to:^{50, level I}

- reduction of asthma exacerbations (RR=0.47, 95% CI 0.35 to 0.63)
- improvement in health-related quality of life scores (MD= -7.00, 95% CI -10.19 to -3.81)

Other controller options:

Long-term OCS may be used in selected patient and should only be initiated by the respiratory physician after a thorough assessment.

Table 5. Low, Medium and High Doses of Inhaled Corticosteroids

Drug	Daily dose (μg)		
	Low	Medium	High
Beclometasone (CFC)*	200 - 500	>500 - 1000	>1000
Commonly used			
Beclometasone (HFA)	100 - 200	>200 - 400	>400
Budesonide (DPI)	200 - 400	>400 - 800	>800
Ciclesonide (HFA)	80 - 160	>160 - 320	>320
Fluticasone propionate (DPI)	100 - 250	>250 - 500	>500
Fluticasone propionate (HFA)	100 - 250	>250 - 500	>500
Less commonly used			
Fluticasone furoate (DPI)	NA	100	200
Mometasone furoate	110 - 220	>220 - 440	>440
Triamcinolone acetonide	400 - 1000	>1000 - 2000	>2000

CFC=chlorofluorocarbon propellant; DPI=dry powder inhaler; HFA= hydrofluoroalkane propellant; NA= not applicable

*Beclometasone (CFC) is included for comparison with older literature.

Modified: Global Initiative for Asthma. Global Strategy for Asthma Management and Prevention, 2017. (Available at www.ginasthma.org)

Table 5 is not a table of equivalence, but of estimated clinical comparability based on published information and available studies. Doses may be different depending on formulation and labelling requirement (metered or emitted dose). Thus, manufacturer information should be reviewed carefully.

Recommendation 6

- Inhaled corticosteroids (ICS) are the preferred maintenance therapy in asthma.
- Initiation of ICS should not be delayed in symptomatic asthma.
- Low dose ICS should be considered in steroid-naïve symptomatic asthma.
- Long-acting β_2 -agonists should not be used as controller monotherapy without ICS in asthma.
- Patients with difficult-to-control asthma should be referred to a respiratory physician.

7. NON-PHARMACOLOGICAL TREATMENT

Non-pharmacological treatments may improve symptom control and/or reduce future risk of asthma exacerbation. There are numerous environmental, dietary and other triggers of asthma. Avoiding these triggers can improve asthma and reduce the requirement for pharmacotherapy.

a. Smoking

All asthmatics who smoke should be strongly encouraged to quit smoking. They should be offered access to counselling and smoking cessation programmes. They should also be encouraged to avoid environmental smoke exposure.¹³ For smoking cessation, refer to the Malaysian CPG on Treatment of Tobacco Use Disorder (Second Edition).⁵¹

b. Vaccination

The degree of protection against exacerbation conferred by influenza and pneumococcal vaccinations is uncertain. There is no significant difference in the risk of pneumococcal or unspecified pneumonia in both pre- and post-vaccination.^{52, level II-2} There is also insufficient evidence to recommend routine pneumococcal vaccination in asthma patients.

Influenza vaccination is safe and not associated with asthma exacerbation.^{53, level I} Patients with moderate to severe asthma are advised to have annual influenza vaccination.¹³ For mild asthma, recommendations should follow that of general vaccination protocol.

c. Breathing exercise

In a Cochrane systematic review, even though evidence reported positive effects of breathing exercises, no reliable conclusion could be drawn on the use of breathing exercises for asthma in clinical practice.

^{54, level I}

d. Caffeine

Caffeine significantly improves airway function modestly, for up to 4 hours, in asthmatics.^{55, level I}

e. Weight loss

Refer to **Section 9.5.4**.

Recommendation 7

- All asthma patients should be advised to quit smoking and offered smoking cessation programme.

8. ACUTE EXACERBATION OF ASTHMA

Acute exacerbation of asthma is defined as progressive or sudden onset of worsening symptoms such as shortness of breath, chest tightness, wheezing and coughing. Early recognition is required to prevent morbidity and mortality as symptoms can progress rapidly to respiratory failure and death.

- Status asthmaticus is a life-threatening and medical emergency situation.

8.1 Assessment of Severity

A focused history and physical examination should be performed along with the initiation of acute treatment. This should include the time of onset, severity of symptoms, current treatment and risk factors of asthma-related death. Further history taking and detailed physical examination can be done after initiation of emergency treatment. Important signs of severe exacerbation of asthma are shown in the box below.

- Signs of severe exacerbation of asthma are:
 - sit forward
 - speak in words or short phrases
 - use of accessory muscles
 - agitation/altered consciousness
 - tachypnoea
 - tachycardia
 - hypoxia
 - silent chest

The severity of these symptoms and signs, in addition to objective measurement of lung function (PEF/FEV1) are used to categorise asthma exacerbations as mild, moderate, severe or life-threatening (refer to **Table 6**).

Table 6. Level of severity of acute exacerbation of asthma

Severity	Clinical features	Clinical parameters
Mild to moderate	<ul style="list-style-type: none"> • Speaks in phrases • Sits up • Not agitated 	<ul style="list-style-type: none"> • Respiratory Rate (RR): 20 - 30/min • PR: 100 - 120/min • O₂ saturation: 90 - 95% • PEF: >50% predicted or best
Severe	<ul style="list-style-type: none"> • Speaks in words • Sits forward • Agitated • Accessory muscles used 	<ul style="list-style-type: none"> • RR: >30/min • PR: >120/min • O₂: Saturation <90% • PEF: <50% predicted or best
Life-threatening	Severe asthma with ANY OF THE FOLLOWING:	
	<ul style="list-style-type: none"> • Drowsy • Confused • Exhaustion • Cyanosis • Hypotension • Silent chest • Poor respiratory effort 	<ul style="list-style-type: none"> • PEF: <33% • PaO₂: <60 mmHg • Normal (30 - 45 mmHg) or raised PaCO₂

- PEF measurement is not necessary in severe and life-threatening asthma.

Modified:

1. Global Initiative for Asthma. Global Strategy for Asthma Management and Prevention, 2017. Available at www.ginasthma.org
2. British Thoracic Society & Scottish Intercollegiate Guidelines Network. British Guideline on the Management of Asthma. Edinburgh: SIGN; 2016

Recommendation 8

- Rapid clinical assessment of severity* should be performed in all acute exacerbation of asthma.
- Asthma treatment should be initiated immediately based on severity of asthma.

*Refer to **Table 6**.

- It is important to identify patients who are at risk of asthma-related deaths. Presence of any of the following indicates an increased risk:¹³
 - history of near-fatal asthma requiring intubation and mechanical ventilation
 - hospitalisation or ED visit for asthma in the past one year
 - currently using or having recently stopped using OCS
 - not currently using ICS
 - overuse of SABAs (>1 canister of salbutamol per month)
 - history of psychiatric disease or psychosocial problems
 - poor adherence with asthma medications and/or poor adherence with (or lack of) a WAAP
 - history of food allergy

8.2 Treatment

The aims of treatment in acute exacerbation of asthma are to achieve rapid improvement of symptoms and prevent mortality. Refer to **Appendix 7 on Common Medications in Asthma** and **Appendix 8 on Inhaler Devices and Techniques**.

8.2.1 Oxygen

Patients with acute exacerbation of asthma are often hypoxaemic. Oxygen should be used in the treatment of severe asthma. Therapy should be titrated to oxygen saturation of 94 - 98%.²⁷ Compared to controlled flow oxygen, high concentration oxygen therapy results in significantly more hypercapnia in patients with severe exacerbations of asthma.^{56, level I}

Pulse oximeter should be used to guide treatment if available. Absence of pulse oximetry should not delay administration of oxygen.²⁷

Recommendation 9

- Oxygen saturation of $\geq 94\%$ should be maintained in all hypoxic asthma patients.

8.2.2 β_2 -agonists

Inhaled β_2 -agonists relieve bronchospasm in acute exacerbation of asthma. This can be administered via pMDI with spacer or nebuliser. High-dose inhaled β_2 -agonists are recommended as first-line agents in acute exacerbation of asthma and should be administered as early as possible.²⁷ Repeated administration of inhaled SABA (4 - 10 puffs every 20 minutes for the first hour) is effective.¹³

In non-life threatening asthma, there is no difference in lung function (peak flow and FEV₁), length of stay in ED and admission between

spacer and nebuliser for delivery of β_2 -agonists.^{57, level I} Spacer has the advantage of reducing aerosolisation of infectious pathogens. Nebuliser has been shown to be responsible for transmission of respiratory infection via droplets.^{58, level III}

In severe and life-threatening asthma, β_2 -agonists should be given via oxygen-driven nebuliser (6 L/hour). Continuous administration of nebulised β_2 -agonists result in clinically important improvements in asthma health outcomes compared to intermittent administration.^{59, level I}

- reduced hospitalisation (RR=0.68, 95% CI 0.5 to 0.9)
- improved pulmonary function [SMD for FEV1=0.3 (95% CI 0.03 to 0.5) and for PEF=0.33 (95% CI 0.1 to 0.50)]

Continuous nebulisation is defined as truly continuous delivery of β_2 -agonists or frequent nebulisations (one nebulisation every 15 minutes or >4 nebulisations per hour). Suggested doses of salbutamol per nebuliser is 2.5 - 5 mg with maximum dose of 10 mg/hour.²⁷

Continuous nebuliser is generally well-tolerated with no clinically important differences observed in pulse rate, blood pressure, tremor and hypokalaemia compared with intermittent nebuliser.^{59, level I}

- pMDI with spacer should not be used in life-threatening asthma.
- Oral SABA should not be used in acute exacerbation of asthma due to their systemic side effects.
- Parenteral β_2 -agonists, in addition to inhaled β_2 -agonists, may have a role in ventilated patients or those with life-threatening asthma²⁷ and should be reserved in patients who do not respond to other treatments.

Recommendation 10

- In acute exacerbation of asthma, inhaled β_2 -agonists is the first-line treatment.
 - In mild to moderate exacerbations, pressurised metered dose inhaler via spacer is the preferred method of delivery.
 - In severe and life-threatening exacerbations, continuous delivery of nebulised oxygen-driven β_2 -agonists should be used.

8.2.3 Ipratropium bromide

The addition of inhaled ipratropium bromide to β_2 -agonists is indicated in moderate to severe exacerbations of asthma in the ED or equivalent care setting.

In a meta-analysis of 16 RCTs with moderate quality, addition of inhaled ipratropium bromide to β_2 -agonists for adults with acute exacerbation of asthma resulted in reduction in hospitalisation (RR=0.68, 95% CI 0.53

to 0.86) and increase in spirometric parameters 60 - 120 minutes after the last treatment (SMD=20.36, 95% CI 20.23 to 20.49).^{60, level I}

The above findings are supported by a recent Cochrane systematic review on adult patients presenting to the ED with an exacerbation of asthma. Combination of SAMA and SABA improved FEV1 (MD=0.25, 95% CI 0.02 to 0.48). It also reduced hospitalisation (RR=0.72, 95% CI 0.59 to 0.86) especially in severe asthma exacerbations. The 23 studies used, however, were rated as unclear or high risk of bias.^{61, level I}

Recommendation 11

- In acute exacerbation of asthma, combination of short-acting muscarinic antagonists and short-acting β_2 -agonists may be given in emergency settings.

8.2.4 Corticosteroids

Corticosteroids reduce inflammation in asthma. This leads to faster resolution of exacerbations and prevention of relapse. Systemic corticosteroids should be given to all patients with an acute exacerbation of asthma.^{13; 27}

Systemic corticosteroids reduce hospital admission rate in acute exacerbation of asthma.

- Administration within one hour of presentation to ED leads to 60% reduction in hospitalisation (OR=0.40, 95% CI 0.21 to 0.78). This benefit is greatest in patients with severe asthma (OR=0.35, 95% CI 0.21 to 0.59) and those who have not received systemic corticosteroids prior to ED presentation (OR=0.37, 95%CI 0.19 to 0.70).^{62, level I}
- There is no improvement in clinical parameters including hospital admission in adding ICS to OCS on discharge home from ED.^{63, level I} However, patients who are prescribed OCS for acute exacerbation of asthma should continue taking their regular ICS until next review.²⁷

The specific duration and dosage regimen of OCS in acute exacerbation of asthma is uncertain due to the absence of high quality of evidence.^{64, level I} The recommended dose is 1 mg/kg prednisolone or equivalent up to a maximum of 50 mg/day for 5 - 7 days.¹³

Systemic corticosteroids are generally well-tolerated.^{62 - 64, level I}

Recommendation 12

- Systemic corticosteroids should be given to all patients with acute exacerbation of asthma. They should be continued for 5 to 7 days.
- Asthma patients prescribed oral corticosteroids should continue their regular inhaled corticosteroids.

8.2.5 Magnesium sulphate

Magnesium sulphate has been used as an adjunct in severe and life-threatening asthma. In acute exacerbation of asthma not responding to initial treatments, two systematic reviews showed that intravenous magnesium sulphate significantly:

- improved pulmonary function^{65 - 66, level I}
- reduced hospitalisation^{65, level I}

A recent RCT supported the above findings.^{67, level I}

In contrast, nebulised magnesium sulphate results in no significant clinical outcomes (pulmonary function and hospitalisation) in addition to standard β_2 -agonist in acute exacerbation of asthma.^{68 - 69, level I}

Recommendation 13

- Intravenous magnesium sulphate should be considered in acute severe and life-threatening asthma.

8.2.6 Other treatments

Other treatments for acute exacerbation of asthma include aminophylline, heliox and mechanical ventilation.

a. Aminophylline

A Cochrane systematic review showed that the addition of IV aminophylline to inhaled β_2 -agonists in adults with acute exacerbation of asthma did not result in significant reduction of hospitalisation (OR=0.58, 95% CI 0.30 to 1.12) or improvement of pulmonary function (MD in PEF= -1.21%, 95% CI -14.21 to 11.78). More over adverse events such as palpitations/arrhythmias (OR=3.02, 95% CI 1.15 to 7.90) and vomiting (OR=4.21, 95% CI 2.20 to 8.07) were more common with its use.^{70, level I}

IV aminophylline should not be routinely used in acute exacerbation of asthma because its lack of efficacy compared with standard therapy and unfavourable side effects.¹³ If its use is required, consultation with a senior physician is advisable.²⁷

b. Heliox

Heliox did not improve pulmonary function or reduce admission compared with standard therapy.^{71, level I}

c. Mechanical ventilation

In acute severe life-threatening asthma with impending respiratory failure, patient should be intubated and referred to critical care.

Non-invasive ventilation is commonly used in acute exacerbation of asthma. However, the evidence supporting its use in asthma is limited.^{72, level I}

- Patients with clinically unstable asthma should be intubated early and referred to critical care.
- There is insufficient evidence to support the use of non-invasive ventilation in acute severe and life-threatening asthma.

8.3 Monitoring and Evaluation

Asthma patients with acute exacerbation need to be monitored and evaluated. The following tests may be used for assessment of asthma severity:²⁷

- **PEF**
 - Measurement of airway calibre
 - Expressed as a percentage of the patient's previous best value or percentage of predicted
 - Measurement will determine severity and treatment (refer to **Algorithm 2** and **Algorithm 3**)
- **Oxygen saturation (SpO₂)**
 - Measured with pulse oximeter to determine the adequacy of oxygen therapy
 - Aim of oxygen therapy is to maintain SpO₂ at 94 - 98% (refer to **Algorithm 2** and **Algorithm 3**)
- **Arterial blood gases (ABG)**
 - Assessment of pH, level of oxygen and carbon dioxide from blood via direct arterial puncture
 - To be performed in life-threatening asthma or SpO₂ <92% (irrespective of whether the patient is on air or oxygen)
 - SpO₂ <92% is associated with a risk of hypercapnia which is not detected by pulse oximeter
- **Chest radiograph**
 - Is recommended in patients with:
 - suspected pneumothorax or pneumomediastinum
 - suspected consolidation
 - failure to respond to treatment
 - life-threatening asthma

Pulsus paradox is defined as a fall of systolic pressure >10 mmHg during inspiratory phase. It is an inadequate indicator for the severity of an attack and should not be used for monitoring an acute exacerbation of asthma.

Recommendation 14

- Monitoring and evaluation of asthma severity should include peak expiratory flow (PEF) and oxygen saturation. In severe and life-threatening asthma:
 - PEF measurement is not necessary
 - arterial blood gases should be done if readily available

8.4 Criteria for admission/discharge

All patients with severe, life-threatening asthma and those with PEF <75% personal best or predicted one hour after initial treatment should be admitted. The following factors may be considered for admission:

- persistent symptoms
- previous near-fatal asthma attack
- living alone/socially isolated
- psychological problems
- physical disability or learning difficulties
- asthma attack despite recent adequate steroid treatment
- pregnancy

It is important to involve a clinician with the appropriate skills in airway management and critical care support as early as possible for acute exacerbation of asthma patients who respond poorly to standard therapy. Consider critical care admission for patients with:²⁷

- deteriorating PEF
- persisting or worsening hypoxia
- hypercapnia
- ABG analysis with worsening acidosis
- exhaustion
- drowsiness, confusion or altered conscious state
- respiratory arrest

Patients with resolution of symptoms and PEF >75% personal best or predicted one hour after initial treatment can be discharged with WAAP.

- Inhaler technique should be checked after an acute exacerbation has resolved. Refer to **Appendix 8 on Inhaler Devices and Techniques**.

Recommendation 15

- All patients with severe, life-threatening asthma and those with peak expiratory flow (PEF) <75% personal best or predicted one hour after initial treatment should be admitted.
- Early referral for critical care should be considered for asthma patients who respond poorly to optimal treatment at-risk of respiratory failure.
- Patients with resolution of symptoms and PEF >75% personal best or predicted one hour after initial treatment may be discharged home with written asthma action plan.

9. SPECIAL GROUPS

9.1 Asthma in Pregnancy

The natural history of asthma during pregnancy is extremely variable. Asthma may worsen, improve or remain unchanged during pregnancy. Asthma is more likely to become severe or to worsen during pregnancy in women with pre-existing severe asthma.

The approach to diagnosis of asthma during pregnancy is the same as to any non-pregnant asthma patient.^{73, level III}

The management of asthma in pregnant patients is the same as for non-pregnant patients, with ICS being the preferred long-term controller medication. The following should be emphasised:

- patient education on good asthma control
- frequent monitoring (4 - 6 weeks)
- maintenance, reliever and anti-leukotriene should be continued
- stepping down medication should be done after delivery if asthma is well controlled

Chest radiography is not contraindicated in pregnancy.²⁷

Asthma exacerbation in pregnancy is managed with oxygen, inhaled β_2 -agonists (inhaled anticholinergics may be added when needed) and possibly systemic corticosteroids.

Respiratory infections should be monitored and managed appropriately during pregnancy. Prompt and adequate treatment is important to avoid foetal hypoxia.¹³ Medicines used to treat asthma can be used normally during breastfeeding.²⁷

- The diagnosis and treatment of asthma during pregnancy is similar to non-pregnant asthma patient.

9.2 Occupational Asthma

Occupational asthma is defined as asthma caused by exposure in the working environment to airborne dusts, vapours or fumes, in workers with or without pre-existing asthma.^{74, level III} On the other hand, work-aggravated asthma is described as pre-existing adult asthma, worsened by nonspecific factors in the workplace, such as cold, dry air, exertion, dust and fumes.⁷⁵

Diagnosis

The diagnosis of occupational asthma is based on the recognition of characteristic symptoms and signs, and the absence of an alternative

explanation for them. The key is to take a careful clinical history specifically on occupation. Serial measurement of PEF should be conducted at least four readings per day, at and away from work, for a period of at least three weeks. A variability of >20% on work days compared to off days is suggestive of work-related asthma.⁷⁵ The diagnosis of occupational asthma should be confirmed by a respiratory physician or a physician with experience in occupational health.

Other diagnostic modalities include specific IgE assays or skin prick test for causative factors and specific inhalation test.⁷⁵

Risk factors

Most frequently reported causative agents include isocyanates, flour and grain dust, colophony and fluxes, latex, animals, aldehydes and wood dust. Workers at increased risk of developing asthma include bakers, food processors, forestry workers, chemical workers, plastics/rubber workers, metal workers, welders, textile workers, electrical/electronic production workers, storage workers, farm workers, waiters, cleaners, painters, dental workers and laboratory technicians.²⁷

Management

Early diagnosis and avoidance of further exposure, either by relocation of the worker or substitution of the hazard offer the best chance of complete recovery. Relocation away from exposure should occur as soon as the diagnosis is confirmed, and ideally within 12 months of the first work-related symptoms of asthma.²⁷

Asthma symptoms are absent after complete removal of exposure with a RR of 21.42 (95% CI 7.20 to 63.77).^{76, level I}

- Under the Act 139 of Factories and Machinery Act, 1967 (Revised - 1974), all occupational asthma cases should be notified to the Department of Occupational Safety and Health.

9.3 Exercise-Induced Bronchoconstriction

Exercise-Induced Bronchoconstriction (EIB) occurs in 10% of general population and up to 90% of patients with asthma. It is more common in persons who participate in sports requiring high minute ventilation such as running and cycling.^{77, level III}

Symptoms of EIB include cough, wheezing, breathlessness or chest tightness. These symptoms occur during or after strenuous exercise and usually peak 5 - 10 minutes after exercise.^{77, level III}

The diagnosis is based on the combination of typical clinical symptoms and demonstration of reversible airflow limitation in response to exercise or a surrogate challenge. It is established by changes in lung function provoked by exercise and not on the basis of symptoms alone. The following tests can be used for the diagnosis:⁷⁸

- Exercise challenge: This involves 6 - 10 minutes of ergometer or treadmill exercise, sufficient to raise the heart rate to 80 - 90% of the predicted maximum. A test is generally considered positive if the FEV1 reduces by ≥ 10 -15%.
- Surrogate provocation tests: Other tests to assess bronchial hyperresponsiveness (e.g. eucapnic voluntary hyperventilation, methacholine, histamine or mannitol inhalation challenge) may be performed in specialised laboratories.

- The diagnosis of EIB requires objective changes in lung function test provoked by exercise.

Medication is the mainstay of treatment in EIB. SABA, administered in a single dose before exercise, is effective and safe in preventing EIB. However, long-term regular administration of inhaled β_2 -agonists induces tolerance and its safety is uncertain due to lack of sufficient data.^{77, level III; 78; 79, level I} Warm-up exercise is recommended.⁷⁸ The optimal treatment of EIB with or without underlying asthma needs more research.^{77, level III} There is no strong evidence to support use of vitamin C and E supplementation in the management of EIB.^{80, level I} There is also no evidence to support the use of ICS/LABA as preventer in EIB.

The summary of diagnosis and treatment of EIB is shown in the **Figure 3** below.

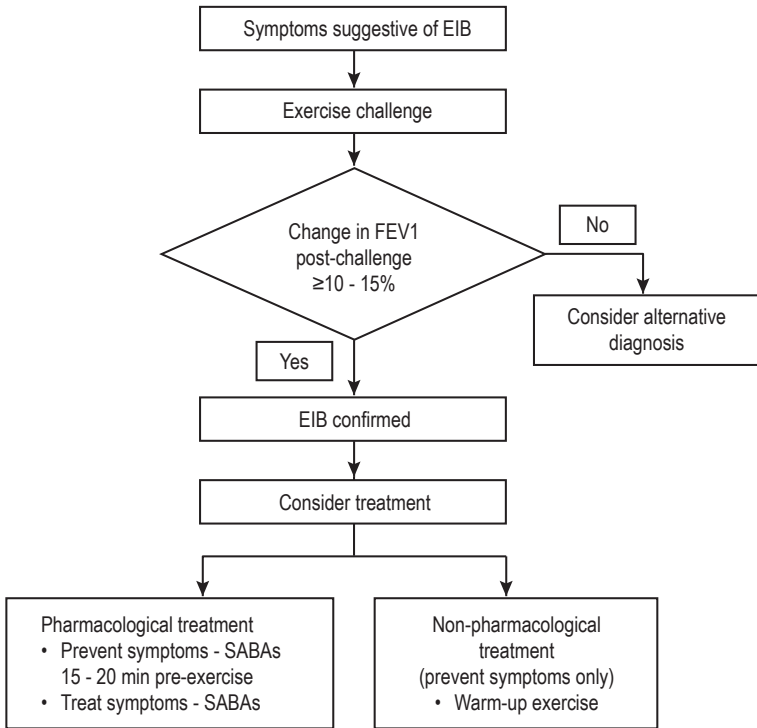

Figure 3. Diagnosis and treatment of EIB

Adapted: Parsons JP, Hallstrand TS, Mastrorarde JG, et al. An official American Thoracic Society clinical practice guideline: exercise-induced bronchoconstriction. *Am J Respir Crit Care Med.* 2013;187(9):1016-27

9.4 Asthma-Chronic Obstructive Pulmonary Disease Overlap

Asthma-chronic obstructive pulmonary disease overlap (ACO) is characterised by persistent airflow limitation with several features usually associated with both asthma and COPD. ACO includes several different clinical phenotypes and there are likely to be several different underlying mechanisms involved.¹³ Refer to **Table 7** for features of asthma, COPD and ACO.

Table 7. Features of asthma, COPD and ACO

Features	Asthma	COPD	ACO
Age (years)	Any age	≥40	≥40
Cigarette smoking	Usually none	≥10 pack years	≥5 pack years
Biomass exposure	Usually none	Yes	Yes especially in women
Family history	Personal history of asthma/family history of asthma, history of allergies	History of exposure to noxious fumes, tobacco and gases	History of doctor-diagnosed asthma, presence of allergies and family history of asthma with or without history of noxious exposures
Past medical history of atopy	Asthma (doctor diagnosed) Allergies	Usually none of these	Asthma (doctor diagnosed) Allergies
Post-bronchodilator response in FEV1	Almost always >12% and 200 ml increase and frequently >12% and 400 ml increase	Unusually >12% and 200 ml increase	Almost always >12% and 200 ml increase but rarely >12% and 400 ml increase

Modified:

- Sin DD. Asthma-COPD Overlap Syndrome: What We Know and What We Don't. *Tuberc Respir Dis (Seoul)*. 2017;80(1):11-20
- Diagnosis of Diseases of Chronic Airflow Limitation: Asthma COPD and Asthma-COPD Overlap Syndrome (ACOS) (Available at ginasthma.org/asthma-copd-and-asthma-copd-overlap-syndrome-acos/)

Treatment objectives are those common to both asthma and COPD individually. The initial treatment of ACO is a combination of ICS/LABA. The addition of tiotropium to a combination of ICS/LABA should be considered if exacerbations and/or significant symptoms persist.^{81, level III}

9.5 Asthma with Co-Morbidities

Management of co-morbidities has important clinical consequences on asthma control because they may contribute to symptom burden. Common co-morbidities such as rhinosinusitis, gastroesophageal reflux and obesity are discussed in this section.

9.5.1 Rhinosinusitis

Asthma is significantly associated with chronic rhinosinusitis (CRS).⁸² CRS can contribute to respiratory symptoms e.g. chronic cough. Treatment of CRS in asthma patients should be targeted at the symptoms rather than to improve asthma control.¹³ Refer to local CPG on Management of Rhinosinusitis in Adolescents and Adults on the treatment of CRS.⁸²

9.5.2 Allergic rhinitis

Evidence supports a link between disease in upper and lower airway. Most patients with asthma have allergic rhinitis and 10 - 40% of patients with allergic rhinitis have asthma.¹³ Patients with moderate-severe persistent allergic rhinitis have an increased risk for severe bronchial hyperreactivity.^{83, level III}

In a meta-analysis of 23 RCTs, adults with allergic rhinitis and steroid-naïve asthma, intranasal corticosteroids (INCS) significantly improved FEV1, bronchial challenge, asthma symptom scores and rescue medication use. There were no significant changes in asthma outcomes with the addition of INCS spray on patients already treated with ICS.^{84, level I}

9.5.3 Gastro esophageal reflux disease

Treatment of GERD has no clear effect on lung function, airway responsiveness or asthma symptom in asthma patients.^{85, level I} A subgroup of patients may benefit but it appears difficult to predict responders.^{86, level I} Patients with poorly control asthma should not be treated with anti-reflux therapy unless they also have symptomatic reflux.¹³

9.5.4 Obesity

Obesity is a major risk factor for the development of asthma. Asthma in obese individuals tends to be more severe and do not respond well to standard asthma treatment.^{87, level III}

Weight loss in obese asthmatics leads to significant improvements in asthma control and lung function (as measured by FEV1, FVC and peak flow). However, this does not appear to correlate with changes in airway inflammation.^{87, level III} In a Cochrane systematic review, one RCT showed that weight loss of 14.5% over 14 weeks weight reduction programme significantly improved dyspnoea and lung function, and reduced the need for short-term reliever medication. However the effects were not sustained at one year follow-up.^{88, level I}

Increasing corticosteroids doses based on poor asthma control may lead to overtreatment with corticosteroids in obese asthmatics. In obese asthmatics, small airway bronchoconstriction may cause airway closure. Thus, greater emphasis should be placed on long-acting bronchodilators.^{89, level III} They also have worsened asthma control with theophylline.^{87, level III} However, montelukast shows some added benefits compared with beclometasone.^{90, level I}

9.5.5 Heart disease

Cardioselective β -blockers given in mild to moderate reversible airway disease has not been shown to affect FEV1, wheezing, dyspnoea or asthma exacerbation.^{91, level I} The initiation of β -blockers does not increase the use of rescue OCS.^{92, level II-2}

Cardioselective β -blockers are not absolute contra-indication for asthma. If clinically indicated (e.g. acute coronary events, heart failure, cardiac arrhythmias, etc.), these agents can be initiated under close supervision of the clinician.¹³

Aspirin can potentially worsen asthma in certain patients (aspirin-exacerbated respiratory disease).¹³ Clinicians should ask patients with asthma for history of reactions to aspirin. Alternatives to aspirin should be considered if there are clinical indications as stated above.

Recommendation 16

- Co-morbidities should be identified and treated appropriately in asthma.
- All suspected occupational asthma should be referred to respiratory physician/physician experienced in occupational health.

9.6 Difficult to Control Asthma

Difficult to control asthma refers to a clinical situation where asthma-like symptoms and asthma attacks persist despite prescription of high-dose asthma therapy.²⁷ It is important to distinguish between severe asthma and difficult to control asthma, as the latter is a much more common reason for persistent symptoms and exacerbations.¹³ The management may include the following:

a. Monoclonal antibodies

Refer to **Section 6.3.2 on Controller therapy (In addition to as-needed reliever inhaler) - Step 5.**

b. Bronchial thermoplasty

Bronchial thermoplasty (BT) is a novel, minimally invasive therapeutic intervention to treat severe persistent asthma which is uncontrolled despite optimal use of medical therapy. It delivers thermal energy to the airway wall to reduce excessive airway smooth muscle.

In a Cochrane systemic review, the advantages of BT at 12 months follow-up compared with conventional treatment were:

- increase in AQLQ scores (MD=0.28, 95% CI 0.07 to 0.50)
- significant decrease in mean frequency of exacerbations

However, BT resulted in increased hospitalisation due to respiratory adverse events during the treatment period (RR=3.50, 95% CI 1.26 to 9.68). After the treatment period, the risk was similar between the groups (RR=1.12, 95% CI 0.44 to 2.85).^{93, level I} This findings were supported in a real-life observational study.^{94, level II-2}

In a 5-year follow-up study of patients who underwent BT, improvements in asthma control were maintained in severe persistent asthma (28% of subjects had $\geq 50\%$ decrease of their ICS maintenance medications). There was no difference for severe exacerbation between subjects reporting seasonal allergy (29.3%) and those with no allergy (29.5%).^{95, level I}

BT is a cost-effective treatment option at five and 10 years, and highly dependent on suitable patients in a study in USA.^{96, level I}

- Bronchial thermoplasty and monoclonal antibodies are treatment options in severe persistent asthma. The use of these modalities are to be decided by respiratory physicians.

10. REFERRAL

It is important to identify the patients who will benefit from being reviewed by specialists with experience in asthma management. This will lead to better care and symptom control. The recommendations in this chapter are formulated based on expert opinion of the CPG DG and on evidence as written in the other chapters in the guidelines.

Recommendation 17

- Asthma patients with the following conditions should be referred to specialists with experience in asthma management for further evaluation:
 - diagnosis of asthma is not clear
 - suspected occupational asthma
 - poor response to asthma treatment
 - persistent use of high-dose inhaled corticosteroids (ICS) without being able to taper off
 - symptoms remain uncontrolled with persistent use of high-dose ICS
 - persistent symptoms despite continuous use of moderate to high dose ICS combined with long-acting β_2 -agonist
 - severe/life-threatening asthma exacerbations
 - asthma in pregnancy
 - asthma with multiple co-morbidities

11. IMPLEMENTING THE GUIDELINES

The management of asthma in adults should be guided by evidence-based approach in order to provide quality care to the patients. Several factors may affect the implementation of recommendations in the CPG.

11.1 Facilitating and Limiting Factors

Existing facilitators for application of the recommendations in the CPG include:

- wide dissemination of the CPG (soft- and hard-copies) to healthcare providers
- regular update on asthma management at conferences and scientific meetings
- lung function test certification programme for healthcare providers
- quality assurance programme on appropriate asthma management in primary care
- public awareness during World Asthma Day
- involvement of non-governmental organisations e.g. Asthma Malaysia

Existing barriers for application of the recommendations of the CPG are:

- limited knowledge and evolving understanding of asthma
- insufficient resources e.g. spirometry, medications and expertise
- lack of dedicated asthma clinic/educator
- variation in treatment practice and preferences
- no national asthma registry for further planning of services

11.2 Potential Resource Implications

To implement the CPG, there must be strong commitment to:

- ensure widespread distribution of the CPG to healthcare providers via printed and electronic copies
- reinforce regular trainings with adequate funding for healthcare providers
- ensure widespread distribution of updated patient education materials

The following is proposed as clinical audit indicator for quality management of asthma:

$$\text{Percentage of adults with newly diagnosed asthma confirmed with spirometry} = \frac{\text{Number of adults with newly diagnosed asthma confirmed with spirometry in a period}}{\text{Number of adults with newly diagnosed asthma in the same period}} \times 100\%$$

$$\text{Percentage of adults with asthma prescribed with written asthma action plan} = \frac{\text{Number of adults with asthma prescribed with written asthma action plan in a period}}{\text{Number of adults with asthma in the same period}} \times 100\%$$

$$\text{Percentage of adults with newly diagnosed symptomatic asthma prescribed with ICS as maintenance treatment} = \frac{\text{Number of adults with newly diagnosed symptomatic asthma prescribed with ICS as maintenance treatment in a period}}{\text{Number of adults with newly diagnosed symptomatic asthma in the same period}} \times 100\%$$

Implementation strategies will be developed following the approval of the CPG by MOH which include launching of the CPG, Quick Reference and Training Module.

REFERENCES

1. To T, Stanojevic S, Moores G, et al. Global asthma prevalence in adults: findings from the cross-sectional world health survey. *BMC Public Health*. 2012;12:204.
2. Institute for Public Health (IPH). The Third National Health and Morbidity Survey 2006 Vol. II. Kuala Lumpur: IPH; 2008.
3. Genes for asthma? An analysis of the European Community Respiratory Health Survey. *Am J Respir Crit Care Med*. 1997;156(6):1773-1780.
4. Vignoud L, Pin I, Boudier A, et al. Smoking and asthma: disentangling their mutual influences using a longitudinal approach. *Respir Med*. 2011;105(12):1805-1814.
5. Künzli N, Kaiser R, Medina S, et al. Public-health impact of outdoor and traffic-related air pollution: a European assessment. *Lancet*. 2000;356(9232):795-801.
6. Orellano P, Quaranta N, Reynoso J, et al. Effect of outdoor air pollution on asthma exacerbations in children and adults: Systematic review and multilevel meta-analysis. *PLoS One*. 2017;12(3):e0174050.
7. Canova C, Jarvis D, Walker S, et al. Systematic review of the effects of domestic paints on asthma related symptoms in people with or without asthma. *J Asthma*. 2013;50(10):1020-1030.
8. Mamane A, Raheison C, Tessier JF, et al. Environmental exposure to pesticides and respiratory health. *Eur Respir Rev*. 2015;24(137):462-473.
9. Beuther DA, Sutherland ER. Overweight, obesity, and incident asthma: a meta-analysis of prospective epidemiologic studies. *Am J Respir Crit Care Med*. 2007;175(7):661-666.
10. Jung HK. Epidemiology of gastroesophageal reflux disease in Asia: a systematic review. *J Neurogastroenterol Motil*. 2011;17(1):14-27.
11. Lötvall J, Ekerljung L, Lundbäck B. Multi-symptom asthma is closely related to nasal blockage, rhinorrhea and symptoms of chronic rhinosinusitis-evidence from the West Sweden Asthma Study. *Respir Res*. 2010;11:163.
12. Lim FL, Hashim Z, Md Said S, et al. Fractional exhaled nitric oxide (FeNO) among office workers in an academic institution, Malaysia--associations with asthma, allergies and office environment. *J Asthma*. 2016;53(2):170-178.
13. Global Initiative for Asthma. Global Strategy for Asthma Management and Prevention, 2017. (Available at www.ginasthma.org).
14. Gibson PG, Powell H, Wilson A, et al. Self-management education and regular practitioner review for adults with asthma. *Cochrane Database of Systematic Reviews* 2002, Issue 3. Art. No.: CD001117.
15. Powell H, Gibson PG. Options for self-management education for adults with asthma. *Cochrane Database Syst Rev*. 2003;(1):CD004107.
16. Gibson PG, Powell H, Coughlan J, et al. Limited (information only) patient education programs for adults with asthma. *Cochrane Database Syst Rev*. 2002;(2):CD001005.
17. Tapp S, Lasserson TJ, Rowe Bh. Education interventions for adults who attend the emergency room for acute asthma. *Cochrane Database Syst Rev*. 2007;(3):CD003000.
18. Gibson PG, Powell H. Written action plans for asthma: an evidence-based review of the key components. *Thorax*. 2004;59(2):94-99.
19. Kew KM, Quinn M, Quon BS, et al. Increased versus stable doses of inhaled corticosteroids for exacerbations of chronic asthma in adults and children. *Cochrane Database Syst Rev*. 2016;(6):CD007524.
20. Armour C, Bosnic-Anticevich S, Brilliant M, et al. Pharmacy Asthma Care Program (PACP) improves outcomes for patients in the community. *Thorax*. 2007;62(6):496-502.
21. Mehuys E, Van Bortel L, De Bolle L, et al. Effectiveness of pharmacist intervention for asthma control improvement. *Eur Respir J*. 2008;31(4):790-799.

22. Wong LY, Chua SS, Husin AR, et al. A pharmacy management service for adults with asthma: a cluster randomised controlled trial. *Fam Pract.* 2017;34(5):564-573.
23. Pharmaceutical Services Division, Ministry of Health Malaysia. Respiratory Medication Therapy Adherence Clinic Protocol: Asthma/COPD (Adult & Paediatric). Kuala Lumpur: MoH; 2015.
24. Pilotto LS, Smith BJ, Heard AR, et al. Trial of nurse-run asthma clinics based in general practice versus usual medical care. *Respirology.* 2004;9(3):356-362.
25. Moullec G, Gour-Provencal G, Bacon SL, et al. Efficacy of interventions to improve adherence to inhaled corticosteroids in adult asthmatics: impact of using components of the chronic care model. *Respir Med.* 2012;106(9):1211-1225.
26. Wilson SR, Strub P, Buist AS, et al. Shared treatment decision making improves adherence and outcomes in poorly controlled asthma. *Am J Respir Crit Care Med.* 2010;181(6):566-577.
27. British Thoracic Society & Scottish Intercollegiate Guidelines Network. British Guideline on the Management of Asthma Edinburgh: SIGN; 2016.
28. Wraight JM, Smith AD, Cowan JO, et al. Adverse effects of short-acting beta-agonists: potential impact when anti-inflammatory therapy is inadequate. *Respirology.* 2004;9(2):215-221.
29. Westby M, Benson M, Gibson P. Anticholinergic agents for chronic asthma in adults. *Cochrane Database Syst Rev.* 2004;(3):CD003269.
30. Kew KM, Karner C, Mindus SM, et al. Combination formoterol and budesonide as maintenance and reliever therapy versus combination inhaler maintenance for chronic asthma in adults and children. *Cochrane Database Syst Rev.* 2013;12:CD009019.
31. Papi A CM, Pigeon-Francisco C, Baronio R, et al. Beclometasone-formoterol as maintenance and reliever treatment in patients with asthma: a double-blind, randomised controlled trial. *Lancet Respir Med.* 2013;1(1):23-31.
32. Manap RA, Loh LC, Ismail TS, et al. Satisfaction levels and asthma control amongst Malaysian asthmatic patients on budesonide/formoterol maintenance and reliever therapy: experience in a real-life setting. *Patient Relat Outcome Meas.* 2012;3:71-78.
33. Cates CJ, Wieland LS, Oleszczuk M, et al. Safety of regular formoterol or salmeterol in adults with asthma: an overview of Cochrane reviews. *Cochrane Database Syst Rev.* 2014;2:CD010314.
34. Pauwels RA, Pedersen S, Busse WW, et al. Early intervention with budesonide in mild persistent asthma: a randomised, double-blind trial. *Lancet.* 2003;361(9363):1071-1076.
35. O'Byrne PM, Barnes PJ, Rodriguez-Roisin R, et al. Low dose inhaled budesonide and formoterol in mild persistent asthma: the OPTIMA randomized trial. *Am J Respir Crit Care Med.* 2001;164(8 Pt 1):1392-1397.
36. Chauhan BF, Ducharme FM. Anti-leukotriene agents compared to inhaled corticosteroids in the management of recurrent and/or chronic asthma in adults and children. *Cochrane Database Syst Rev.* 2012;(5):CD002314.
37. Dahl R, Larsen BB, Venge P. Effect of long-term treatment with inhaled budesonide or theophylline on lung function, airway reactivity and asthma symptoms *Respir Med.* 2002;96(6):432-438.
38. Ducharme FM, Ni Chroinin M, Greenstone I, et al. Addition of long-acting beta2-agonists to inhaled steroids versus higher dose inhaled steroids in adults and children with persistent asthma. *Cochrane Database Syst Rev.* 2010;(4):CD005533.
39. Stempel DA, Raphiou IH, Kral KM, et al. Serious Asthma Events with Fluticasone plus Salmeterol versus Fluticasone Alone. *N Engl J Med.* 2016;374(19):1822-1830.

40. Peters SP, Bleeker ER, Canonica GW, et al. Serious Asthma Events with Budesonide plus Formoterol vs. Budesonide Alone. *N Engl J Med.* 2016;375(9):850-860.
41. Chauhan BF, Ducharme FM. Addition to inhaled corticosteroids of long-acting beta2-agonists versus anti-leukotrienes for chronic asthma. *Cochrane Database Syst Rev.* 2014;1:CD003137.
42. Tee AK, Koh MS, Gibson PG, et al. Long-acting beta2-agonists versus theophylline for maintenance treatment of asthma. *Cochrane Database Syst Rev.* 2007;(3):CD001281.
43. Philip G, Nayak AS, Berger WE, et al. The effect of montelukast on rhinitis symptoms in patients with asthma and seasonal allergic rhinitis. *Curr Med Res Opin.* 2004;20(10):1549-1558.
44. Rodrigo GJ, Castro-Rodríguez JA. What is the role of tiotropium in asthma?: a systematic review with meta-analysis *Chest.* 2015;147(2):388-396.
45. Anderson DE, Kew KM, Boyter AC. Long-acting muscarinic antagonists (LAMA) added to inhaled corticosteroids (ICS) versus the same dose of ICS alone for adults with asthma. *Cochrane Database of Systematic Reviews* 2015, Issue 8. Art. No.: CD011397.
46. Kew KM, Evans DJ, Allison DE, et al. Long-acting muscarinic antagonists (LAMA) added to inhaled corticosteroids (ICS) versus addition of long-acting beta2-agonists (LABA) for adults with asthma. *Cochrane Database Syst Rev.* 2015;6:CD011438.
47. Kew KM, Dahri K. Long-acting muscarinic antagonists (LAMA) added to combination long-acting beta2-agonists and inhaled corticosteroids (LABA/ICS) versus LABA/ICS for adults with asthma. *Cochrane Database Syst Rev.* 2016;(1):CD011721.
48. Normansell R, Walker S, Milan SJ, et al. Omalizumab for asthma in adults and children. *Cochrane Database of Systematic Reviews* 2014, Issue 1. Art. No.: CD003559.
49. Chen HC, Huang CD, Chang E, et al. Efficacy of omalizumab (Xolair®) in patients with moderate to severe predominately chronic oral steroid dependent asthma in Taiwan: a retrospective, population-based database cohort study. *BMC Pulm Med.* 2016;16:3.
50. Powell C, Milan SJ, Dwan K, et al. Mepolizumab versus placebo for asthma. *Cochrane Database of Systematic Reviews* 2015, Issue 7. Art. No.: CD010834.
51. Ministry of Health, Malaysia. *Treatment of Tobacco Use Disorder.* Putrajaya: MoH; 2016.
52. Lee TA, Weaver FM, Weiss KB. Impact of pneumococcal vaccination on pneumonia rates in patients with COPD and asthma. *J Gen Intern Med.* 2007;22(1):62-67.
53. Cates CJ, Rowe BH. Vaccines for preventing influenza in people with asthma. *Cochrane Database Syst Rev.* 2013;(2):CD000364.
54. Freitas DA, Holloway EA, Bruno SS, et al. Breathing exercises for adults with asthma. *Cochrane Database Syst Rev.* 2013;(10):CD001277.
55. Welsh EJ, Bara A, Barley E, et al. Caffeine for asthma. *Cochrane Database Syst Rev.* 2010;(1):CD001112.
56. Perrin K, Wijesinghe M, Healy B, et al. Randomised controlled trial of high concentration versus titrated oxygen therapy in severe exacerbations of asthma. *Thorax.* 2011;66(11):937-941.
57. Cates CJ, Welsh EJ, Rowe BH. Holding chambers (spacers) versus nebulisers for beta-agonist treatment of acute asthma. *Cochrane Database Syst Rev.* 2013;9:CD000052.
58. Lee N, Hui D, Wu A, et al. A major outbreak of severe acute respiratory syndrome in Hong Kong. *N Engl J Med.* 2003;348(20):1986-1994.

59. Camargo CA Jr, Spooner CH, Rowe BH. Continuous versus intermittent beta-agonists in the treatment of acute asthma. *Cochrane Database Syst Rev.* 2003;(4):CD001115.
60. Rodrigo GJ, Castro-Rodriguez JA. Anticholinergics in the treatment of children and adults with acute asthma: a systematic review with meta-analysis. *Thorax.* 2005;60(9):740-6. Erratum in: *Thorax.* 2006;61(3):274. *Thorax.* 2008 Nov;63(11):1029. *Thorax.* 2006;61(5):458. *Thorax.* 2010 Dec;65(12):1118.
61. Kirkland SW, Vandenberghe C, Voaklander B, et al. Combined inhaled beta-agonist and anticholinergic agents for emergency management in adults with asthma. *Cochrane Database of Systematic Reviews* 2017, Issue 1. Art. No.: CD001284.
62. Rowe BH, Spooner C, Ducharme FM, et al. Early emergency department treatment of acute asthma with systemic corticosteroids. *Cochrane Database Syst Rev.* 2001;(1):CD002178.
63. Edmonds ML, Milan SJ, Brenner BE, et al. Inhaled steroids for acute asthma following emergency department discharge. *Cochrane Database Syst Rev.* 2012;12:CD002316.
64. Normansell R, KewKM, Mansour G. Different oral corticosteroid regimens for acute asthma. *Cochrane Database of Systematic Reviews* 2016, Issue 5. Art. No.: CD011801.
65. Kew KM, Kirtchuk L, Michell CI. Intravenous magnesium sulfate for treating adults with acute asthma in the emergency department. *Cochrane Database Syst Rev.* 2014;5:CD010909.
66. Mohammed S, Goodacre S. Intravenous and nebulised magnesium sulphate for acute asthma: systematic review and meta-analysis. *Emerg Med J.* 2007;24(12):823-830.
67. Hossein S, Pegah A, Davood F, et al. The effect of nebulized magnesium sulfate in the treatment of moderate to severe asthma attacks: a randomized clinical trial. *Am J Emerg Med.* 2016;34(5):883-886.
68. Blitz M, Blitz S, Beasley R, et al. Inhaled magnesium sulfate in the treatment of acute asthma. *Cochrane Database Syst Rev.* 2005;(4):CD003898. Review. Update in: *Cochrane Database Syst Rev.* 2012;12:CD003898 12;12:CD004360.
69. Ling ZG, Wu YB, Kong JL, et al. Lack of efficacy of nebulized magnesium sulfate in treating adult asthma: A meta-analysis of randomized controlled trials. *Pulm Pharmacol Ther.* 2016;41:40-47.
70. Nair P, Milan SJ, Rowe BH. Addition of intravenous aminophylline to inhaled beta(2)-agonists in adults with acute asthma. *Cochrane Database Syst Rev.* 2012;12:CD002742.
71. Rodrigo G, Pollack C, Rodrigo C, et al. Heliox for nonintubated acute asthma patients. *Cochrane Database Syst Rev.* 2006;(4):CD002884.
72. Lim WJ, Mohammed Akram R, Carson KV, et al. Non-invasive positive pressure ventilation for treatment of respiratory failure due to severe acute exacerbations of asthma. *Cochrane Database Syst Rev.* 2012;12:CD004360.
73. Kelly W, Massoumi A, Lazarus A. Asthma in pregnancy: Physiology, diagnosis, and management *Postgrad Med.* 2015;127(4):349-358.
74. Sauni R, Kauppi P, Helaskoski E, et al. Audit of quality of diagnostic procedures for occupational asthma. *Occup Med (Lond).* 2009;59(4):230-236.
75. Nicholson PJ, Cullinan P, Burge S. British Occupational Health Research Foundation. Concise guidance: diagnosis, management and prevention of occupational asthma. *Clin Med (Lond).* 2012;12(2):156-159.
76. de Groene GJ, Pal TM, Beach J, et al. Workplace interventions for treatment of occupational asthma. *Cochrane Database Syst Rev.* 2011;(5):CD006308.
77. Krafczyk MA, Asplund CA. Exercise-induced bronchoconstriction: diagnosis and management. *Am Fam Physician.* 2011;84(4):427-434.

78. Parsons JP, Hallstrand TS, Mastronarde JG, et al. An official American Thoracic Society clinical practice guideline: exercise-induced bronchoconstriction. *Am J Respir Crit Care Med*. 2013;187(9):1016-1027.
79. Bonini M, Di Mambro C, Calderon MA, et al. Beta₂-agonists for exercise-induced asthma. *Cochrane Database Syst Rev*. 2013;(10):CD003564.
80. Wilkinson M, Hart A, Milan SJ, et al. Vitamins C and E for asthma and exercise-induced bronchoconstriction. *Cochrane Database Syst Rev*. 2014;(6):CD010749.
81. Plaza V, Álvarez F, Calle M, et al. Consensus on the Asthma-COPD Overlap Syndrome (ACOS) Between the Spanish COPD Guidelines (GesEPOC) and the Spanish Guidelines on the Management of Asthma (GEMA). *Arch Bronconeumol*. 2017;53(8):443-449.
82. Ministry of Health, Malaysia. Management of Rhinosinusitis in Adolescents and Adults Putrajaya: MoH; 2016.
83. Cirillo I, Pistorio A, Tosca M, et al. Impact of allergic rhinitis on asthma: effects on bronchial hyperreactivity. *Allergy*. 2009;64(3):439-444.
84. Lohia S, Schlosser RJ, Soler ZM. Impact of intranasal corticosteroids on asthma outcomes in allergic rhinitis: a meta-analysis. *Allergy*. 2013;68(5):569-579.
85. Gibson PG, Henry RL, Coughlan JL. Gastro-oesophageal reflux treatment for asthma in adults and children. *Cochrane Database Syst Rev*. 2003;(2):CD001496.
86. Coughlan JL, Gibson PG, Henry RL. Medical treatment for reflux oesophagitis does not consistently improve asthma control: a systematic review. *Thorax*. 2001;56(3):198-204.
87. Dixon AE, Holguin F, Sood A, et al. An official American Thoracic Society Workshop report: obesity and asthma. *Proc Am Thorac Soc*. 2010;7(5):325-335.
88. Adeniyi FB, Young T. Weight loss interventions for chronic asthma. *Cochrane Database of Systematic Reviews* 2012, Issue 7. Art. No.: CD009339.
89. Gibson PG. Obesity and asthma. *Ann Am Thorac Soc*. 2013;10 Suppl:S138-142.
90. Peters-Golden M, Swern A, Bird SS, et al. Influence of body mass index on the response to asthma controller agents. *Eur Respir J*. 2006;27(3):495-503.
91. Salpeter SR, Ormiston TM, Salpeter EE, et al. Cardioselective beta-blockers for reversible airway disease. *Cochrane Database of Systematic Reviews* 2002, Issue 4. Art. No.: CD002992.
92. Arboe B, Ulrik CS. Beta-blockers: friend or foe in asthma? *Int J Gen Med*. 2013;6:549-555.
93. Torrego A, Solà I, Munoz AM, et al. Bronchial thermoplasty for moderate or severe persistent asthma in adults. *Cochrane Database Syst Rev*. 2014;(3):CD009910.
94. Bicknell S, Chaudhuri R, Lee N, et al. Effectiveness of bronchial thermoplasty in severe asthma in 'real life' patients compared with those recruited to clinical trials in the same centre. *Ther Adv Respir Dis*. 2015;9(6):267-271.
95. Wechsler ME, Lavolette M, Rubin AS, et al. Bronchial thermoplasty: Long-term safety and effectiveness in patients with severe persistent asthma. *J Allergy Clin Immunol*. 2013;132(6):1295-1302.
96. Zein JG, Menegay MC, Singer ME, et al. Cost effectiveness of bronchial thermoplasty in patients with severe uncontrolled asthma. *J Asthma*. 2016;53(2):194-200.

Appendix 1

EXAMPLE OF SEARCH STRATEGY

The following Medical Subject Heading terms or free text terms were used either singly or in combination, search limits were English, human, "all adult (19 plus years)" and last 15 years:

Clinical Question: What should be included in a written asthma action plan?

1. ASTHMA/
2. (bronchial adj1 asthma).tw.
3. asthma*.tw.
4. 1 or 2 or 3
5. SELF CARE/
6. self manage*.tw.
7. (self adj1 (manage* or care)).tw.
8. self-manage*.tw.
9. self-care.tw.
10. action plan.tw.
11. PATIENT CARE PLANNING/
12. (plan* patient adj1 care).tw.
13. patient care plan*.tw.
14. plan* nursing care.tw.
15. nursing care plan*.tw.
16. care goal*.tw.
17. goals of care.tw.
18. PATIENT EDUCATION AS TOPIC/
19. (education adj1 patient*).tw.
20. patient education as topic.tw.
21. DISEASE MANAGEMENT/
22. (disease adj1 manage*).tw.
23. 5 or 6 or 7 or 8 or 9 or 10 or 11 or 12 or 13 or 14 or 15 or 16 or 17 or 18 or 19 or 20 or 21 or 22
24. 4 and 23

Appendix 2**CLINICAL QUESTIONS**

1. What is the prevalence/incidence of asthma in adults?
2. What are the risk factors of asthma in adults?
3. What are the diagnostic criteria of asthma in adults?
4. What are the differential diagnoses of asthma in adults?
5. What are the treatment goals of asthma in adults?
6. What is the role of patient self-management in control of asthma in adults?
7. What should be included in a written asthma action plan?
8. What is the effective patient education modality for asthma in adults?
9. What is the definition of stable asthma in adults?
10. What are the criteria to step up or step down treatment for asthma in adults?
11. What are the effectiveness and safety of the following pharmacological interventions for stable asthma in adults?
 - short-acting β -agonists
 - single maintenance and reliever therapy
 - long-acting β -agonists
 - inhaled corticosteroids
 - leukotriene receptor antagonists
 - theophylline
 - combination of ICS/LABA
 - anti-cholinergic inhalers
 - cromones
12. How to assess acute exacerbation of asthma?
13. How to grade severity of acute exacerbation of asthma?
14. What are the effectiveness and safety of the following interventions for acute exacerbation of asthma in adults?
 - oxygen
 - β -agonists
 - ipratropium bromide
 - corticosteroids
 - magnesium sulphate
 - aminophylline
 - heliox
 - mechanical ventilation

15. What is the effective and safe treatment in the following special conditions of asthma in adults?
 - Asthma in pregnancy
 - Occupational asthma
 - Exercise-induced asthma
 - Asthma-COPD overlap
 - Asthma with co-morbidities
 - Difficult to control asthma
16. What are the referral criteria of asthma to respiratory physicians?

Appendix 3

PEAK EXPIRATORY FLOW RATE VARIABILITY

PEF measurement may be performed in either a sitting or standing position.

PEF is the best of three (3) forced expiratory blows from maximum inhalation.

Record the morning best three (3) PEF measurement and the evening best three (3) PEF measurement.

Diurnal variation of PEF = $\frac{\text{Highest PEF evening} - \text{Lowest PEF morning}}{\text{Mean PEF}} \times 100\%$

The PEF variability over two (2) weeks is calculated by taking the highest PEF minus the lowest PEF divided by the average PEF over two weeks multiplied by one hundred. A variability of **more than 20%** is a **positive test for asthma**.

Example of mean variability over two (2) weeks:

Day	PEF measurement (L/min)
Sunday	240
Monday	260
Tuesday	300
Wednesday	320
Thursday	330
Friday	250
Saturday	400
Sunday	300
Monday	450
Tuesday	320
Wednesday	370
Thursday	350
Friday	340
Saturday	350

Variability over 2 weeks = $\frac{\text{Highest PEF} - \text{Lowest PEF}}{\text{Average PEF}} \times 100\%$

$$= \frac{450 - 240}{327.1} \times 100$$

$$= \mathbf{64.2\%}$$

Appendix 4

PEAK EXPIRATORY FLOW NOMOGRAM

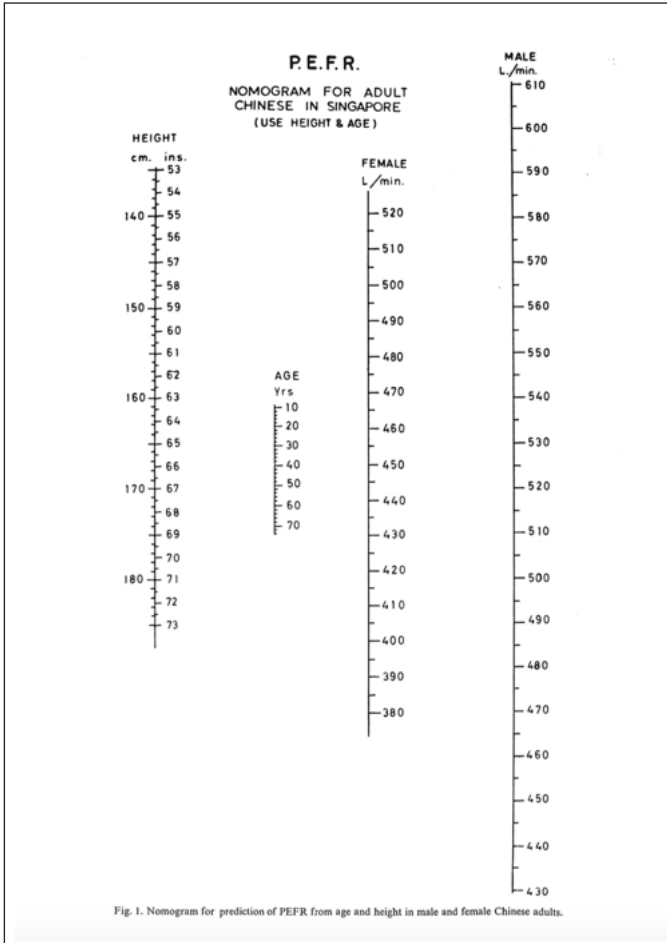

Mark the patient's height and age on the respective lines. Draw a straight line connecting the two points and extend this line to the corresponding gender line to get the expected PEF value.



Modified: Da Costa JL, Goh BK. Peak expiratory flow rate in normal adult Chinese in Singapore. Singapore Med J. 1973;14(4):511-4

WRITTEN ASTHMA ACTION PLAN

Name: _____ IC: _____ Personal Best PEF: _____ L/min Date of Plan: _____
 Doctor: _____ Hospital/Clinic: _____ Phone No.: _____

<p> Green: Doing Well</p> <ul style="list-style-type: none"> No cough, wheeze, chest tightness or shortness of breath day/night AND Sleep well at night AND Can do usual activities <p>OR</p> <ul style="list-style-type: none"> PEF: _____ to _____ L/min (80% to 100% of personal best) 	<p>• Take these controller medications everyday:</p> <table border="1"> <thead> <tr> <th>Controller medication</th> <th>How Much</th> <th>How Often</th> </tr> </thead> <tbody> <tr><td> </td><td> </td><td> </td></tr> <tr><td> </td><td> </td><td> </td></tr> <tr><td> </td><td> </td><td> </td></tr> <tr><td> </td><td> </td><td> </td></tr> <tr><td> </td><td> </td><td> </td></tr> </tbody> </table> <p>*Use spacer when possible</p>	Controller medication	How Much	How Often															
Controller medication	How Much	How Often																	
<p> Yellow: Getting Worse</p> <ul style="list-style-type: none"> Cough, wheeze, chest tightness or shortness of breath OR Wake up at night due to asthma symptoms OR Can do some, but not all usual activities OR Cold/flu <p>OR</p> <ul style="list-style-type: none"> PEF: _____ to _____ L/min (50% to 79% of personal best) 	<p>• Take your regular medications and step up reliever medication for 1 hour:</p> <table border="1"> <thead> <tr> <th>Reliever Medication</th> <th>How Much</th> <th>How Often</th> </tr> </thead> <tbody> <tr> <td> </td> <td> </td> <td>Every 20 minutes</td> </tr> </tbody> </table> <ul style="list-style-type: none"> If your symptoms persist after 1 hour: <ul style="list-style-type: none"> Start prednisolone (if available): _____ tablets daily for 5 days (maximum dose 50 mg/day) Continue using your reliever medication and go to the nearest hospital or clinic <p>*Use spacer when possible</p>	Reliever Medication	How Much	How Often			Every 20 minutes												
Reliever Medication	How Much	How Often																	
		Every 20 minutes																	
<p> Red: Alert</p> <ul style="list-style-type: none"> Symptoms are worsening (cough, wheeze, chest tightness, shortness of breath, cannot do usual activities) OR You are using your reliever frequently: <ul style="list-style-type: none"> every 2 to 3 hours OR more than 8 puffs a day <p>OR</p> <ul style="list-style-type: none"> PEF: Below _____ L/min (Less than 50% of personal best) 	<p>• Continue using your reliever medication:</p> <table border="1"> <thead> <tr> <th>Reliever Medication</th> <th>How Much</th> <th>How Often</th> </tr> </thead> <tbody> <tr> <td> </td> <td> </td> <td> </td> </tr> </tbody> </table> <ul style="list-style-type: none"> Start prednisolone NOW (if have not started); maximum dose 50 mg/day Go to the nearest hospital or clinic IMMEDIATELY/dial 999 <p>*Use spacer when possible</p>	Reliever Medication	How Much	How Often															
Reliever Medication	How Much	How Often																	

Appendix 6

ASTHMA CONTROL TEST™

Asthma Control Test provides a numerical score to determine the control of asthma symptoms.

1.	In the past 4 weeks, how much of the time did your asthma keep you from getting as much done at work, school or at home?					Score
	All of the time (1)	Most of the time (2)	Some of the time (3)	A little of the time (4)	None of the time (5)	
2.	During the past 4 weeks, how often have you had shortness of breath?					Score
	More than once a day (1)	Once a day (2)	3 to 6 times a week (3)	Once or twice a week (4)	Not at all (5)	
3.	During the past 4 weeks, how often did your asthma symptoms (wheezing, coughing, shortness of breath, chest tightness or pain) wake you up at night or earlier than usual in the morning?					Score
	4 or more nights a week (1)	2 to 3 nights a week (2)	Once a week (3)	Once or twice (4)	Not at all (5)	
4.	During the past 4 weeks, how often had you used your rescue inhaler or nebuliser?					Score
	3 or more times per day (1)	1 to 2 times per day (2)	2 or 3 times per week (3)	Once a week or less (4)	Not at all (5)	
5.	How would you rate your asthma control in the last 4 weeks?					Score
	Not controlled at all (1)	Poorly controlled (2)	Somewhat controlled (3)	Well controlled (4)	Completely controlled (5)	

Total score: _____

Modified: © Asthma Control Test™ (Available at: <http://www.asthma.com/additional-resources/asthma-control-test.html?q=asthma+control+test>)

UJIAN KAWALAN ASMA™

1.	Dalam 4 minggu kebelakangan ini, berapa kerapkah asma anda menghalang anda daripada melakukan sebanyak mungkin di tempat kerja, sekolah atau di rumah?					Markah
	Sepanjang masa (1)	Kebanyakan masa (2)	Kadang-kadang (3)	Sedikit masa (4)	Tiada langsung (5)	
2.	Sepanjang tempoh 4 minggu yang lalu, berapa kerapkah anda telah mengalami sesak nafas?					Markah
	Lebih daripada sekali sehari (1)	Sekali sehari (2)	3 hingga 6 kali seminggu (3)	Sekali atau dua kali seminggu (4)	Tiada langsung (5)	
3.	Sepanjang 4 minggu yang lalu, berapa kerapkah gejala asma (berdehit/ <i>wheezing</i> , batuk, sesak nafas, sesak dada atau sakit) menyebabkan anda terbangun pada waktu malam atau lebih awal dari biasa di waktu pagi?					Markah
	4 malam atau lebih seminggu (1)	2 hingga 3 malam seminggu (2)	Sekali seminggu (3)	Sekali atau dua kali (4)	Tiada langsung (5)	
4.	Sepanjang tempoh 4 minggu yang lalu, berapa kerapkah anda telah menggunakan ubat sedut yang melegakan dengan cepat atau nebuliser anda (seperti sabutamol, terbutaline atau fenoterol)?					Markah
	3 kali atau lebih sehari (1)	1 atau 2 kali sehari (2)	2 atau 3 kali seminggu (3)	Sekali seminggu atau kurang (4)	Tiada langsung (5)	
5.	Bagaimana anda menilai kawalan asma anda sepanjang tempoh 4 minggu yang lalu?					Markah
	Tidak terkawal langsung (1)	Kawalan adalah buruk (2)	Agak terkawal (3)	Terkawal dengan baik (4)	Terkawal sepenuhnya (5)	

Markah Keseluruhan: _____

Modified: © Asthma Control Test™ (Available at: <http://www.asthma.com/additional-resources/asthma-control-test.html?q=asthma+control+test>)

COMMON MEDICATIONS IN ASTHMA*
A. INHALED SHORT-ACTING β_2 -AGONISTS (SABA)

DRUG	DOSAGE	COMMON ADVERSE DRUG REACTIONS	COMMENTS
Salbutamol 100 µg/dose inhaler, pMDI	<ul style="list-style-type: none"> For relief of acute bronchospasm, 1 to 2 inhalations (maximum: 8 inhalations/day) 	<ul style="list-style-type: none"> Tremor, headache, tachycardia 	<ul style="list-style-type: none"> Reliever
Salbutamol 100 and 200 µg/dose inhaler, Easyhaler® (DPI)	<ul style="list-style-type: none"> For relief of acute bronchospasm, 1 inhalation as a single starting dose; may be increased to 2 inhalations if necessary 	<ul style="list-style-type: none"> Tremor, palpitation, tachycardia 	<ul style="list-style-type: none"> Reliever

B. INHALED CORTICOSTEROIDS (ICS)

DRUG	DOSAGE	COMMON ADVERSE DRUG REACTIONS	COMMENTS
Beclometasone dipropionate 50, 100 and 200 µg/dose inhaler, pMDI	Extra-fine formulation: <ul style="list-style-type: none"> 50 to 200 µg twice/day; increased if necessary up to 400 µg twice/day (maximum daily dose: 800 µg) 	<ul style="list-style-type: none"> Oropharyngeal candidiasis, hoarseness of voice, pharyngitis, taste disturbance 	<ul style="list-style-type: none"> Controller
Beclometasone dipropionate 200 µg/dose inhaler, Easyhaler® (DPI)	<ul style="list-style-type: none"> 200 to 400 µg twice/day If needed, the dose can be increased up to 1600 µg/day 	<ul style="list-style-type: none"> Oropharyngeal candidiasis, hoarseness of voice, cough, throat irritation 	<ul style="list-style-type: none"> Controller
Budesonide 100 and 200 µg/dose inhaler, pMDI	<ul style="list-style-type: none"> 200 to 1600 µg/day in two divided doses 	<ul style="list-style-type: none"> Oropharyngeal candidiasis, mild throat irritation, hoarseness of voice, cough 	<ul style="list-style-type: none"> Controller

<p>Budesonide 100 and 200 µg/dose inhaler, Easyhaler® (DPI)</p>	<p>Twice/day dosing:</p> <ul style="list-style-type: none"> • 200 to 1600 µg/day in divided doses <p>Once/day dosing (mild to moderate asthma, previously stabilised on twice/day dose):</p> <ul style="list-style-type: none"> • 200 to 400 µg once/day (maximum per dose: 800 µg) 	<ul style="list-style-type: none"> • Oropharyngeal candidiasis, cough, throat irritation, difficulty in swallowing 	<ul style="list-style-type: none"> • Controller
<p>Budesonide 100 and 200 µg/dose inhaler, Turbuhaler® (DPI)</p>	<p>Twice/day dosing:</p> <ul style="list-style-type: none"> • 200 to 1600 µg/day in divided doses <p>Once/day dosing (mild to moderate asthma, previously stabilised on twice/day dose):</p> <ul style="list-style-type: none"> • 200 to 400 µg once/day (maximum per dose: 800 µg) 	<ul style="list-style-type: none"> • Oropharyngeal candidiasis, cough, hoarseness of voice, throat irritation 	<ul style="list-style-type: none"> • Controller
<p>Ciclesonide 80 and 160 µg/dose inhaler, pMDI</p>	<ul style="list-style-type: none"> • 160 µg once/day; in severe asthma, a higher dose of up to 640 µg/day (given as 320 µg twice/day) may be used 	<ul style="list-style-type: none"> • Uncommon: dry mouth, dysphonia, headache, cough, bad taste, oropharyngeal candidiasis 	<ul style="list-style-type: none"> • Controller
<p>Fluticasone propionate 50 and 125 µg/dose inhaler, pMDI</p>	<ul style="list-style-type: none"> • 100 to 1000 µg twice/day <p>Starting doses:</p> <ul style="list-style-type: none"> • 100 µg twice/day (mild asthma) • 250 to 500 µg twice/day (moderate and more severe asthma) • Up to 1000 µg twice/day may be used where additional clinical benefit is expected 	<ul style="list-style-type: none"> • Oropharyngeal candidiasis, hoarseness of voice/dysphonia, bruises 	<ul style="list-style-type: none"> • Controller

C. INHALED CORTICOSTEROID/LONG-ACTING β_2 -AGONISTS COMBINATION (ICS/LABA)

DRUG	DOSAGE	COMMON ADVERSE DRUG REACTIONS	COMMENTS
Beclometasone dipropionate 100 μ g and formoterol 6 μ g inhaler, pMDI	<p>Maintenance therapy:</p> <ul style="list-style-type: none"> 1 to 2 inhalations twice/day (maximum: 4 inhalations/day) <p>Maintenance and reliever therapy:</p> <ul style="list-style-type: none"> Maintenance dose is 1 inhalation twice/day with additional 1 inhalation as needed in response to symptoms If symptoms persist after a few minutes, an additional inhalation should be taken Maximum daily dose: 8 inhalations 	<ul style="list-style-type: none"> Oropharyngeal candidiasis, headache, dysphonia, pharyngitis 	<ul style="list-style-type: none"> Controller (can be used as single inhaler for maintenance and reliever therapy)
Budesonide 160 μ g and formoterol 4.5 μ g inhaler, Turbuhaler® (DPI)	<p>Maintenance therapy:</p> <ul style="list-style-type: none"> 1 to 2 inhalations twice/day. Some patients may require up to a maximum of 4 inhalations twice/day <p>Maintenance and reliever therapy:</p> <ul style="list-style-type: none"> 2 inhalations/day, given either as one inhalation in the morning and evening or as 2 inhalations in either the morning or evening For some patients, a maintenance dose of 2 inhalations twice/day may be appropriate Patient should take 1 additional inhalation as needed in response to symptoms. If symptoms persist after a few minutes, an additional inhalation should be taken. Not more than 6 inhalations should be taken on any single occasion 	<ul style="list-style-type: none"> Oropharyngeal candidiasis, hoarseness of voice, headache, tremor, mild throat irritation, cough, palpitation 	<ul style="list-style-type: none"> Controller (can be used as single inhaler for maintenance and reliever therapy)

	<ul style="list-style-type: none"> • A total daily doses of >8 inhalations is not normally needed; however, a total daily dose of up to 12 inhalations could be used for a limited period. Patients using >8 inhalations/day are strongly recommended to seek medical advice. • 1 inhalation twice/day • Some patients may require up to a maximum of 2 inhalations twice/day • 2 inhalations twice/day 		<ul style="list-style-type: none"> • Controller
Budesonide 320 µg and formoterol 9 µg inhaler, Turbuhaler® (DPI)			
Fluticasone propionate 125 µg and formoterol 5 µg inhaler, pMDI		<ul style="list-style-type: none"> • Uncommon: headache, tremor, dizziness, palpitation, dysphonia, throat irritation, dry mouth 	<ul style="list-style-type: none"> • Controller • Licensed for adults and adolescents aged ≥12 years
Fluticasone propionate 250 µg and formoterol 10 µg inhaler, pMDI			<ul style="list-style-type: none"> • Controller • Licensed for adults aged ≥18 years
Fluticasone furoate 100 µg and vilanterol 25 µg inhaler, Ellipta® (DPI)	<ul style="list-style-type: none"> • 1 inhalation once/day 	<ul style="list-style-type: none"> • Headache, nasopharyngitis, oropharyngeal candidiasis, influenza, upper respiratory tract infection, dysphonia, cough 	<ul style="list-style-type: none"> • Controller
Fluticasone furoate 200 µg and vilanterol 25 µg inhaler, Ellipta® (DPI)			
Salmeterol 25 µg and fluticasone propionate 50 µg inhaler, pMDI	<ul style="list-style-type: none"> • 2 inhalations twice/day 		<ul style="list-style-type: none"> • Controller
Salmeterol 25 µg and fluticasone propionate 125 µg inhaler, pMDI			
Salmeterol 25 µg and fluticasone propionate 250 µg inhaler, pMDI			

Salmeterol 50 µg and fluticasone propionate 100 µg inhaler, Accuhaler® (DPI)	• 1 inhalation twice/day	• Controller
Salmeterol 50 µg and fluticasone propionate 250 µg inhaler, Accuhaler® (DPI)		
Salmeterol 50 µg and fluticasone propionate 500 µg inhaler, Accuhaler® (DPI)		

D. LONG-ACTING MUSCARINIC ANTAGONISTS (LAMA)

DRUG	DOSAGE	COMMON ADVERSE DRUG REACTIONS	COMMENTS
Tiotropium 2.5 µg, solution for inhalation, Respimat® (Soft Mist Inhaler®)	• 2 inhalations (5 µg) once/day, at the same time of the day	<ul style="list-style-type: none"> • Dry mouth • Uncommon: headache, dizziness, insomnia, palpitations, pharyngitis, cough 	• Controller

E. LEUKOTRIENE RECEPTOR ANTAGONISTS (LTRA)

DRUG	DOSAGE	COMMON ADVERSE DRUG REACTION	COMMENTS
Montelukast 10 mg tablet	• 10 mg once/day (in the evening)	<ul style="list-style-type: none"> • Upper respiratory tract infection, headache, abdominal pain, diarrhoea, pyrexia, elevated levels of serum transaminases (alanine transaminase, aspartate transaminase) 	• Controller

F. THEOPHYLLINE

DRUG	DOSAGE	COMMON ADVERSE DRUG REACTION	COMMENTS
Theophylline Sustained Release (SR) 250 mg tablet	<ul style="list-style-type: none"> • 250 mg twice/day • Suggested starting dose is 250 mg once/day 	<ul style="list-style-type: none"> • Gastric irritation, nausea, vomiting, anorexia, epigastric pain, reactivation of peptic ulcer, gastro-oesophageal reflux, haematemesis, tachycardia, palpitation, headache, central nervous system stimulation, reflex hyperexcitability, insomnia, tremor 	<ul style="list-style-type: none"> • Controller • Clearance may be decreased in elderly, acute pulmonary oedema, heart failure, liver disease (refer drug database for complete information) • Potentially significant drug-drug interactions may exist (refer drug interaction database for complete information)

G. NEBULISER

DRUG	DOSAGE	COMMON ADVERSE DRUG REACTIONS	COMMENTS
Ipratropium bromide 0.0125% Nebulising solution (125 µg/ml)	<p>Acute exacerbation of asthma*:</p> <ul style="list-style-type: none"> • 500 µg: repeated doses can be administered (4 to 6 hourly) .The time interval between the doses may be determined by the physician. • It is advisable not to exceed the recommended daily dose. • Daily doses exceeding 2 mg should only be given under medical supervision. 	<p>Headache, dizziness, throat irritation, cough, dry mouth, disturbance in gastrointestinal motility, nausea</p>	<p>*Refer to Algorithm 2 and 3 in the CPG</p>
Ipratropium bromide 0.025% Inhalation solution (250 µg/ml)			

Salbutamol 0.5 % Inhalation solution	<p>Acute exacerbation of asthma*:</p> <ul style="list-style-type: none"> • 2.5 to 5 mg every 20 minutes for the first hour (3 doses), then 2.5 to 10 mg every 1 to 4 hours as needed, or 10 to 15 mg/hour by continuous nebulisation. 	Tremor, headache, tachycardia	*Refer to Algorithm 2 and 3 in the CPG
Ipratropium bromide 0.5 mg and Salbutamol 2.5 mg per UDV (Unit Dose Vial)	<p>Acute exacerbation of asthma:</p> <ul style="list-style-type: none"> • 1 UDV every 4 to 6 hours 	<p>Uncommon:</p> <p>Headache, throat irritation, cough, tachycardia, tremor, nervousness, dry mouth, dysphonia</p>	

#Disclaimer: The information on common asthma medications in this section only serves as a general guide and is not all-inclusive. Doses may be different depending on formulation.



Source:

1. The electronic Medicines Compendium (eMC) (Available at <https://www.medicines.org.uk/emc/>)
2. Medication package insert.
3. Drug Information Databases (Available at <http://www.wolterskluwerdi.com/lexicomp-online/databases/>)
4. BMA & Royal Pharmaceutical Society. British National Formulary (BNF) 73 March – September 2017. London: BMJ Group & Pharmaceutical Press: 2017
5. Formulari Ubat KKM (FUKKM) (Available at <https://www.pharmacy.gov.my/v2/ms/apps/fukkm>)
6. Micromedex® Solutions (Available at <http://www.micromedexsolutions.com/micromedex2/ilibrarian>)
7. Monthly Index of Medical Specialities (MIMS) (Available at <https://online1.mimsgateway.com.my/Malaysia/membership/index?returnUrl=https%3a%2f%2fonline1.mimsgateway.com.my%2f>)

APPENDIX 8

INHALER DEVICES AND TECHNIQUES

- Inhaler techniques must be checked and corrected at every single opportunity. Patients need to sit or stand up straight with head tilted slightly backwards during inhalation from an inhaler.

	pMDI	pMDI AND SPACER (VHC)***	RESPIMAT®
PRIMING (ONCE before first use and when inhaler has not been used for a period of time*)	 <p>Remove the cap, shake the inhaler well**, and release several puffs* into the air.</p>	 <p>Pre-wash is not necessary for antistatic spacers. However, standard plastic spacer need to be pre-washed (soak) with diluted mild detergent (do not rinse) and air-dried before first use to reduce electrostatic charge. Wipe the mouthpiece before use.</p>	 <p>Keep inhaler upright with the cap closed. Turn the clear base in the direction of the red arrows until it clicks. Then flip the cap open. Point the inhaler towards the ground. Press the grey button and close the cap. Repeat the above steps until a cloud is visible and continue these steps three more times.</p>
INHALATION TECHNIQUE	<p>1. Hold inhaler upright. Remove the cap and shake the inhaler well**. Breathe out completely and slowly, away from the inhaler.</p>	<p>1. Remove the cap. Hold inhaler upright and shake well**. Insert inhaler upright into spacer.</p>	<p>1. Hold inhaler upright with the cap closed. Turn the base in the direction of the red arrow until it clicks. Then flip the cap open.</p> <p>2. Breathe out completely and slowly (away from inhaler).</p> <p>3. Put mouthpiece between teeth without biting it and close lips to form good seal without covering the air vent. Point inhaler to the back of the throat.</p>
		<p>Spacer with mouthpiece:</p> <p>2. Put mouthpiece between teeth without biting it and close lips to form good seal.</p>	
		<p>Spacer with mask:</p> <p>2. Apply mask to face and ensure an effective seal over mouth and nose.</p>	

	<p>2. Put mouthpiece between teeth without biting it; with the tongue flat under the mouthpiece and close lips to form good seal.</p> <p>3. Start to inhale slowly, through the mouth and at the same time press firmly the canister to actuate a dose. Maintain a slow and deep inhalation, until the lungs are full of air (this should take 4 to 5 seconds).</p> <p>4. Remove the inhaler from the mouth and hold breath for 10 seconds or as long as comfortable (at least 5 seconds). Then breathe out slowly away from inhaler.</p>	<p>3. Breathe out gently, into the spacer. Press the canister ONCE at the beginning of a slow inhalation.</p> <p>Spacer with mouthpiece:</p> <p>4. Single Breath Method: Breathe in slowly and deeply. Remove the spacer from the mouth and hold breath for 10 seconds or as long as comfortable (at least 5 seconds). Then breathe out gently.</p> <p>OR</p> <p>Tidal Breathing Method:</p>	<p>4. While taking in a slow and deep breathe through the mouthpiece, press the dose release button and continue to breathe in slowly and deeply.</p>	<p>5. Remove the inhaler from the mouth and hold breath for 10 seconds or as long as comfortable (at least 5 seconds), then breathe out slowly (away from inhaler).</p>
		<p>Spacer with mask:</p> <p>4. Tidal Breathing Method: Breathe in and out normally for 5 breaths*. Remove spacer from mouth. Breathe out gently.</p>		
	<p>5. Repeat steps 1 to 4 if more than one dose is required. Wait at least 30 seconds before another dose. Recap the inhaler after use.</p>	<p>5. Repeat steps 1 to 4 if more than one dose is required. Remove the inhaler from the spacer, and recap the inhaler.</p>		<p>6. Repeat steps 1 to 5 for a second dose. Recap the inhaler after use.</p>

CLEANING	Clean at least once a week; cleaning instruction varies*	Clean at least once a week; cleaning instruction varies*	Clean at least once a week. Clean the mouthpiece including the metal part inside the mouthpiece with a damp cloth or tissue only. If necessary, wipe the outside of inhaler with a damp cloth.
ADDITIONAL INFORMATION	After each inhalation of ICS, rinse the mouth with water, gargle and spit out the water.		

*Varies from product to product. Refer to manufacturer's recommendations.

**Vigorous shaking of the pMDI immediately before each actuation is very important in ensuring reproducible delivery of the optimal respirable dose, with medications formulated as suspensions. Shaking is unnecessary for pMDI in a true solution formulation; however advising patients to shake all pMDIs in the same manner may simplify patient education.

***Spacers are accessory devices to be used with pMDIs. Spacers that incorporate a one-way-valve are called VHCs. Tidal breathing can be performed with VHCs.

DRY POWDER INHALERS (DPIs)

- DPIs are breath-actuated, hence patients do not have to coordinate actuation with inhalation.
- **Deep and forceful inhalation** at the start of inspiration is needed to create turbulent energy within the device, which de-agglomerates the powder into fine particles.
- This turbulent energy is created by patient's inspiratory flow and internal resistance of the inhaler device.
- Sufficient inspiratory flow is needed for optimal drug delivery.

	ACCUHALER®	EASYHALER®	ELLIPTA®	TURBUHALER®
PRIMING (ONCE before first use)	No priming required.	No priming required.	No priming required.	Perform step 1 twice. The inhaler is now ready to use. To take a dose, continue according to instructions below (start from Step 1).
INHALATION TECHNIQUE	<ol style="list-style-type: none"> 1. Hold the inhaler horizontally. Open cover by pushing the thumb grip until a "click" sound is heard, then load dose by sliding lever until it clicks again. Do not tilt or shake the device once loaded. 	<ol style="list-style-type: none"> 1. Remove the cap and shake the inhaler well. Keep the inhaler upright with the mouthpiece down. Press the inhaler completely until a "click" sound is heard. Release the inhaler to return to the original position. 	<ol style="list-style-type: none"> 1. Hold the inhaler upright with the cover on the top. Slide the cover down until a "click" sound is heard. Do not shake the device. 	<ol style="list-style-type: none"> 1. Unscrew and lift off the cover. Hold the inhaler upright with the coloured grip downwards. Turn the grip all the way in one direction and then backwards until "click" is heard. Do not shake or drop the device.

	2. Breathe out completely and slowly, away from the inhaler.	3. Place the mouthpiece between teeth and seal lips around the mouthpiece.	3. Place the mouthpiece between teeth and close lips to form good seal. Make sure the air vents are facing upwards. Do not cover air vents.	3. Place the mouthpiece horizontally between teeth and seal lips around the mouthpiece. Do not cover air vents.
	4. Breathe in forcefully and deeply.	4. Breathe in forcefully and deeply.	4. Breathe in with one long, steady and deep breath.	4. Breathe in forcefully and deeply.
	5. Remove the inhaler from the mouth and hold breath for 10 seconds or as long as comfortable (at least 5 seconds). Then breathe out slowly (away from inhaler).	6. Slide thumb grip back to its original position until a "click" sound is heard.	6. Repeat steps 1 to 5 if more than one dose is required. Recap the mouthpiece.	6. Repeat steps 1 to 5 if more than one dose is required. Cover the inhaler after use.
CLEANING ADDITIONAL INFORMATION	The mouthpiece can be cleaned with a dry cloth/tissue. Never use water or liquid.	<ul style="list-style-type: none"> If accidentally released more than one dose, remove it from the mouthpiece by tapping it against a hard surface. 	<ul style="list-style-type: none"> Clean the mouthpiece immediately after inhalation, before sliding back the cover. 	<ul style="list-style-type: none"> Do not hold the mouthpiece when turning the grip.
After each inhalation of ICS, rinse the mouth with water, gargle and spit out the water.				

Primary source:

The above information has been adapted from the National Asthma Council Australia's inhaler technique, device-specific checklists. This information was developed for an Australian audience, and the accuracy in other countries may vary. The full checklist can be found at: <https://www.nationalasthma.org.au/living-with-asthma/resources/health-professionals/charts/inhaler-technique-checklists>.

Other sources:

- The Aerosol Drug Management Improvement Team (ADMIT) (Internet communication, 10 August 2017 at <http://www.admit-inhalers.org/>)
- Initiative Helping Asthma in Real-life Patients (IHarp) (Internet communication, 31 April 2017 at <http://iharp.org/>)
- Laube BL, Janssens HM, de Jongh FH, et al. What the pulmonary specialist should know about the new inhalation therapies. Eur Respir J. 2011;37(6):1308-31
- Levy ML, Dekhuijzen P, Barnes PJ, et al. Inhaler technique: facts and fantasies. A view from the Aerosol Drug Management Improvement Team (ADMIT). NPJ Prim Care Respir Med. 2016;26:16028
- The electronic Medicine Compendium (eMC) (Available at <http://www.medicines.org.uk/emc/>)
- FDA Online Label Repository (Available at <http://labels.fda.gov/>)
- Price DB, Roman-Rodriguez M, McQueen RB, et al. Inhaler Errors in the CRITICAL Study: Type, Frequency, and Association with Asthma Outcomes. J Allergy Clin Immunol Pract. 2017;5(4):1071-1081.

LIST OF ABBREVIATIONS

β_2 -agonists	beta 2-agonists
μg	microgramme
ABG	arterial blood gases
ACO	asthma-chronic obstructive pulmonary disease overlap
ACT	Asthma Control Test
AQLQ	Asthma Quality of Life Questionnaire
BT	bronchial thermoplasty
CCM	Chronic Care Model
CI	confidence interval
COPD	chronic obstructive pulmonary disease
CPG(s)	clinical practice guidelines
CRS	chronic rhinosinusitis
DG	Development Group
DPI(s)	Dry Powder Inhaler(s)
ED	Emergency Department
EIB	exercise-induced bronchoconstriction
FeNO	fractional exhaled nitric oxide
FEV1	forced expiratory volume in 1 second
FVC	forced vital capacity
GERD	Gastro Esophageal Reflux Disease
GINA	Global Initiative for Asthma
GOLD	Global Initiative for Chronic Obstructive Lung Disease
INCS	intranasal corticosteroids
ICS	inhaled corticosteroids
IgE	immunoglobulin E
kg	kilogramme
kU/L	kilounit/litre
LABA	long-acting β_2 -agonists
LTRA	leukotriene receptor antagonists
MD	mean difference
mg	milligramme
mcg	microgramme
min	minutes
ml	millilitre
mmHg	millimetre mercury
MoH	Ministry of Health
MTS	Malaysian Thoracic Society
O ₂	oxygen
OCS	oral corticosteroids
OR(s)	odds ratio(s)
PC ₂₀	provocative concentration needed to produce a 20% fall in FEV1 from baseline
ppb	parts per billion
PEF(R)	peak expiratory flow (rate)
pH	potential of hydrogen
pMDI	pressurised metered-dose inhaler
PR	pulse rate
RC	Review Committee
RCT(s)	randomised controlled trial(s)
RR	relative risk

SABA	short-acting β_2 -agonists
SAMA	short-acting muscarinic antagonists
SMD	standardised mean difference
SpO ₂	oxygen saturation on pulse oximetry
vs	versus
WAAP	written asthma action plan

ACKNOWLEDGEMENT

The DG members of these guidelines would like to express their gratitude and appreciation to the following for their contributions:

- Panel of external reviewers who reviewed the draft
- Technical Advisory Committee of CPG for their valuable input and feedback
- All those who have contributed directly or indirectly to the development of the CPG
- Ms. Rosnani Abdul Latip on retrieval of evidence and Ms. Noormah Darus on critical appraisal in the CPG development
- Mr. Terance Tay Kian Shuh, Mr. Hilmi Abdullah and Dr. Leong Swee Wei for the design of the CPG cover

DISCLOSURE STATEMENT

The panel members of both DG and RC had completed disclosure forms. None held shares in pharmaceutical firms or acts as consultants to such firms. (Details are available upon request from the CPG Secretariat)

SOURCE OF FUNDING

The development of the CPG on Management of Asthma in Adults was supported financially mainly by the MoH Malaysia and to some extent by the Malaysian Thoracic Society. The printing was funded by the Malaysian Thoracic Society.

**MALAYSIAN HEALTH TECHNOLOGY
ASSESSMENT SECTION**

Medical Development Division
Ministry of Health Malaysia
Level 4, Block E1, Precinct 1
62590 Putrajaya, Malaysia

ISBN 978-967-2173-14-4

